



RoHS
Compliant
2002/95/EC

REV.	ECN. NO.	APPD.

MODEL CODE

ATI-001-DW16-***P-000-08P*-**
1 2 3 4 5 6 7 8 9 10 11

DIMENSIONS

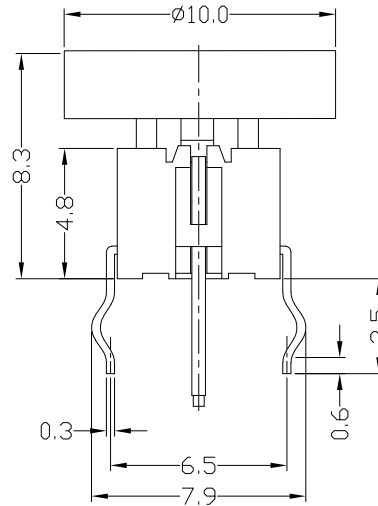
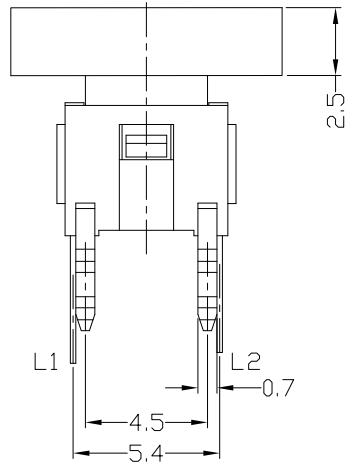
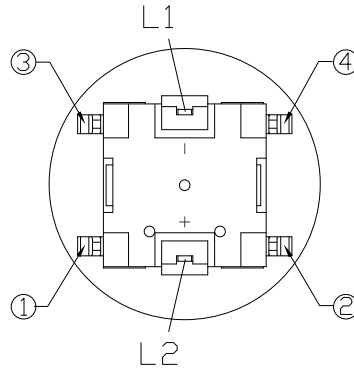
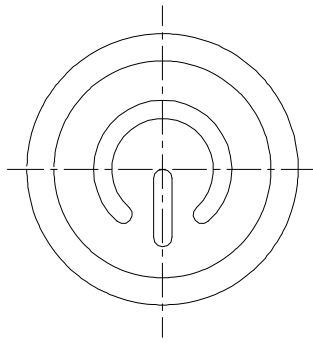

- Series Number
- Terminal Type: D=Dip M=SMT
- Stem Color: W=White B=Black
- Operating Force: 16=160gf 25=250gf
- LED Color: 01=Red 02=Yellow 03=Green
04=Blue 05=White 06=Pure Green
08=Amber 09=Blue Green
0A=Pink 0B=Purple
- LDE Appearance: P=Flat
- HOUSING Code: 00=Without
- HOUSING Color: 0=Without B=Black
- CAP Code
- CAP Color: B=Black C=Milky
- Laser Engraving Pattern: 00=Without
01=Power Symbol
02=Power
03=Reset

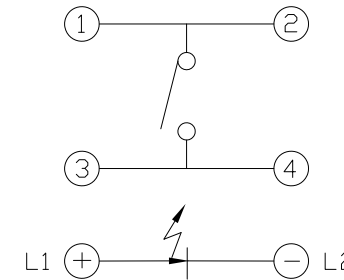

SCHEMATIC

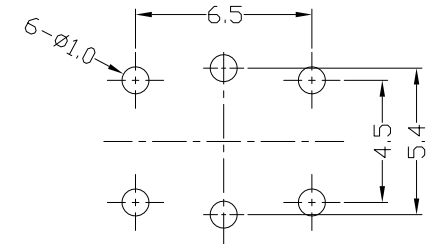

P.C.B LAYOUT

NO.	PARTS	MATERIAL	Q'TY	FINISHING
8				
7				
6	CAP	ABS	1	
5	LED		1	
4	CONTACT	PBS C5210R-EH	1	Ag CLAD
3	TERMINAL	BRASS STRIP	4	Ag PLATED
2	CASE	NYLON+F.G	1	BLACK
1	KNOB	NYLON+F.G	1	WHITE/BLACK

WITHIN 1.5mm: ±0.2mm
OVER 1.5mm: ±0.3mm

THESE DRAWINGS AND SPECIFICATIONS ARE THE PROPERTY OF ACCURATE INNOTECH INC AND SHALL NOT BE REPRODUCED, COPIED OR USED IN ANY MANNER WITHOUT THE PRIOR WRITTEN CONSENT OF ACCURATE INNOTECH INC.

UNITS	mm
MAT'L	SEE NOTE
FINISH	SEE NOTE
Q'TY	

雅安科技有限公司 ACCURATE INNOTECH INC.			
TITLE: ILLUMINATED TACT SWITCH+CAP		PART NO.: ATI-001-DXX-XXP-000-08PX-XX	
DR: <i>Ricky</i> 2022/05/31		DWG NO.: AZJ-001-D-08P	
CHKD: <i>Ricky</i> 2022/05/31		SCALE: 4:1	SHEET: 1/1
APPD:		REV.: A	CUSTOMER DRAWING



RoHS
Compliant
2002/95/EC

REV.	ECN. NO.	APPD.

MODEL CODE

ATI-001-MW16-***P-000-08P*-**
1 2 3 4 5 6 7 8 9 10 11

- Series Number
- Terminal Type: D=Dip M=SMT
- Stem Color: W=White B=Black
- Operating Force: 16=160gf 25=250gf
- LED Color: 01=Red 02=Yellow 03=Green
04=Blue 05=White 06=Pure Green
08=Amber 09=Blue Green
0A=Pink 0B=Purple
- LDE Appearance: P=Flat
- HOUSING Code: 00=Without
- HOUSING Color: 0=Without B=Black
- CAP Code
- CAP Color: B=Black C=Milky
- Laser Engraving Pattern: 00=Without
01=Power Symbol
02=Power
03=Reset

DIMENSIONS

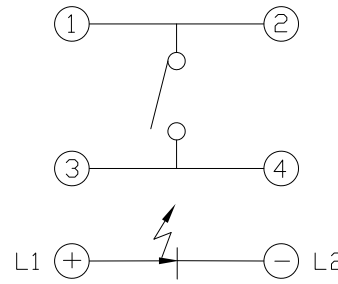
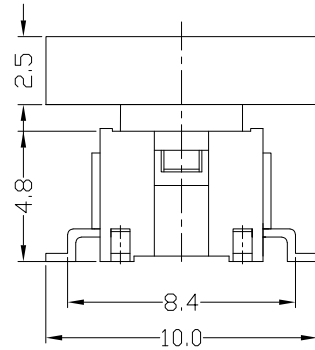
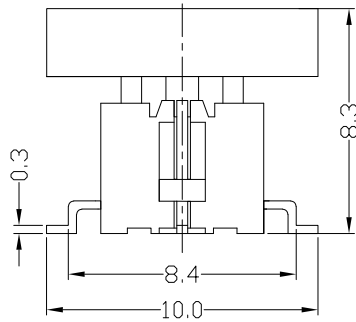
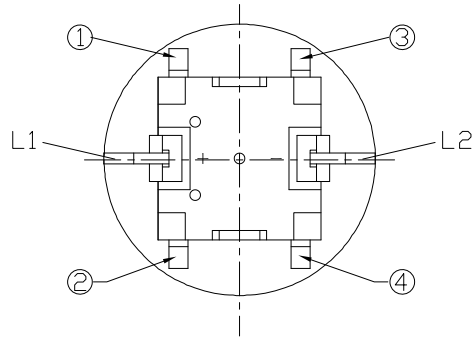
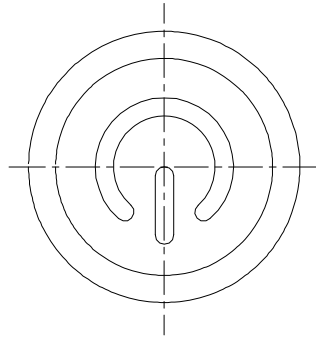

SCHEMATIC

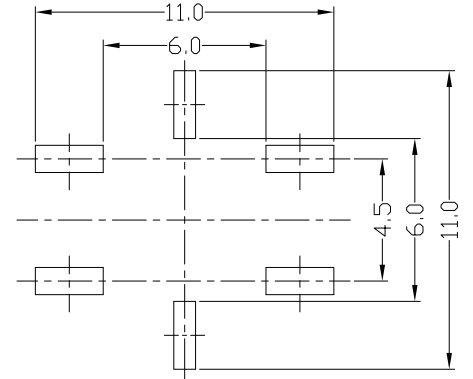

P.C.B. LAYOUT

NO.	PARTS	MATERIAL	Q'TY	FINISHING
8				
7				
6	CAP	ABS	1	
5	LED		1	
4	CONTACT	PBS C5210R-EH	1	Ag CLAD
3	TERMINAL	BRASS STRIP	4	Ag PLATED
2	CASE	NYLON+F.G	1	BLACK
1	KNOB	NYLON+F.G	1	WHITE

WITHIN 1.5mm: ±0.2mm	UNITS mm
OVER 1.5mm: ±0.3mm	MAT'L
	SEE NOTE
	FINISH
	SEE NOTE
	Q'TY

THESE DRAWINGS AND SPECIFICATIONS ARE THE PROPERTY OF ACCURATE INNOTECH INC AND SHALL NOT BE REPRODUCED, COPIED OR USED IN ANY MANNER WITHOUT THE PRIOR WRITTEN CONSENT OF ACCURATE INNOTECH INC.

雅安科技有限公司 ACCURATE INNOTECH INC.			
TITLE: ILLUMINATED TACT SWITCH+CAP		PART NO.: ATI-001-MXX-XXP-000-08PX-XX	
DR: Ricky 2022/05/31		DWG NO.: AZJ-001-M-08P	
CHKD: Ricky 2022/05/31		SCALE: 4:1	SHEET: 1/1
APPD:		REV.: A	CUSTOMER DRAWING



RoHS
Compliant
2002/95/EC

REV.	ECN. NO.	APPD.

MODEL CODE

ATI-007-DW16-**P-000-08P*-**
1 234 56 78 9 10 11

DIMENSIONS

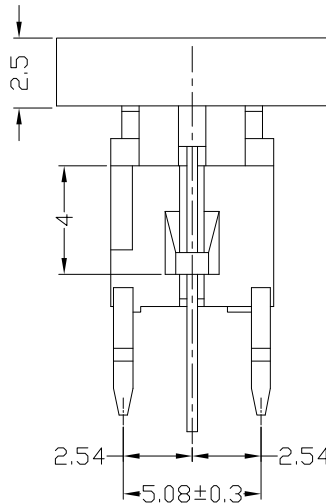
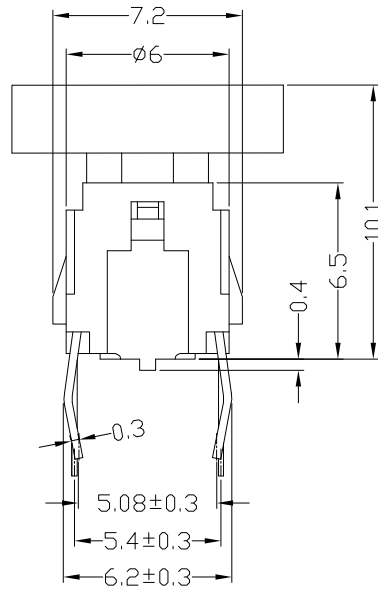
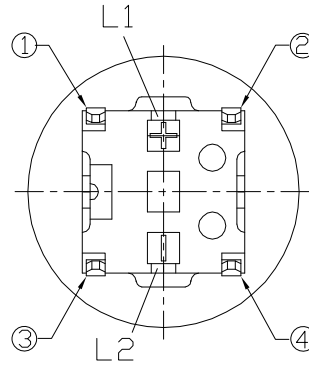
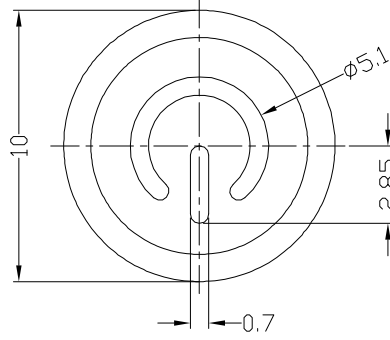

- Series Number
- Terminal Type: D=Dip M=SMT
- Stem Color: W=White B=Black
- Operating Force: 16=160gf 25=250gf
- LED Color: 01=Red 02=Yellow 03=Green
04=Blue 05=White 06=Pure Green
08=Amber 09=Blue Green
0A=Pink 0B=Purple
- LDE Appearance: P=Flat
- HOUSING Code: 00=Without
- HOUSING Color: 0=Without B=Black
- CAP Code
- CAP Color: B=Black C=Milky
- Laser Engraving Pattern: 00=Without
01=Power Symbol
02=Power
03=Reset

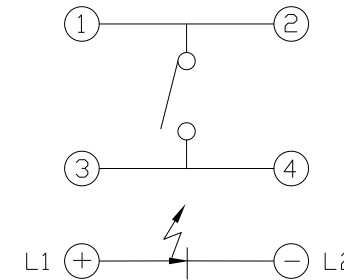

SCHEMATIC

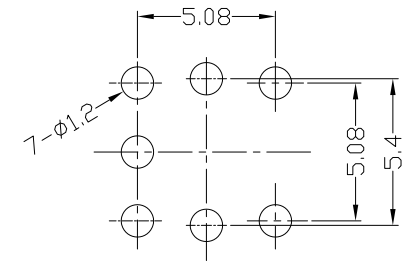

P.C.B LAYOUT

NO.	PARTS	MATERIAL	Q'TY	FINISHING
8				
7				
6	CAP	ABS	1	
5	LED		1	
4	CONTACT	PBS C5210R-EH	1	Ag CLAD
3	TERMINAL	BRASS STRIP	4	Ag PLATED
2	CASE	NYLON+F.G	1	BLACK
1	KNOB	NYLON+F.G	1	BLACK

WITHIN 1.5mm: ±0.2mm	UNITS mm
OVER 1.5mm: ±0.3mm	MAT'L
	SEE NOTE
	FINISH
	SEE NOTE
THESE DRAWINGS AND SPECIFICATIONS ARE THE PROPERTY OF ACCURATE INNOTECH INC AND SHALL NOT BE REPRODUCED, COPIED OR USED IN ANY MANNER WITHOUT THE PRIOR WRITTEN CONSENT OF ACCURATE INNOTECH INC.	Q'TY

雅安科技有限公司 ACCURATE INNOTECH INC.			
TITLE: ILLUMINATED TACT SWITCH+CAP		PART NO.: ATI-007-DXX-XXP-000-08PX-XX	
DR: Ricky 2022/05/31		DWG NO.: AZJ-007-D-08P	
CHKD: Ricky 2022/05/31		SCALE: 4:1	SHEET: 1/1
APPD:		REV.: A	CUSTOMER DRAWING



RoHS
Compliant
2002/95/EC

REV.	ECN. NO.	APPD.

MODEL CODE

ATI-007-MB16-***P-000-08P*-**
1 234 56 78 9 10 11

DIMENSIONS

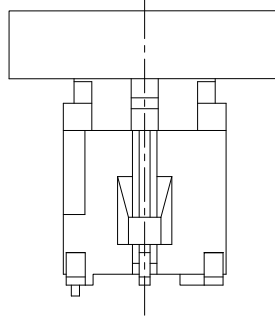
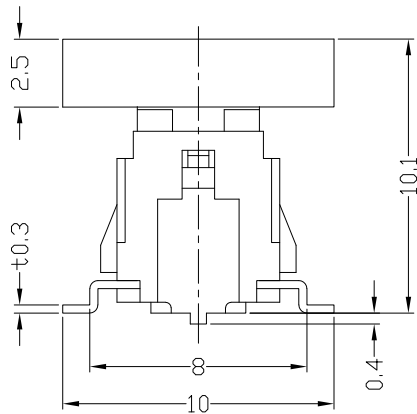
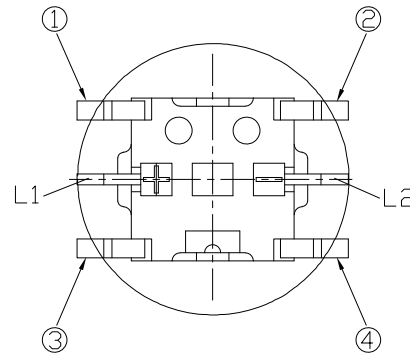
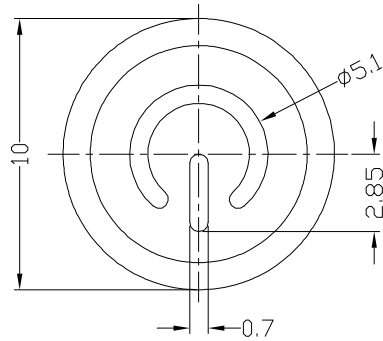

- Series Number
- Terminal Type: D=Dip M=SMT
- Stem Color: W=White B=Black
- Operating Force: 16=160gf 25=250gf
- LED Color: 01=Red 02=Yellow 03=Green
04=Blue 05=White 06=Pure Green
08=Amber 09=Blue Green
0A=Pink 0B=Purple
- LDE Appearance: P=Flat
- HOUSING Code: 00=Without
- HOUSING Color: 0=Without B=Black
- CAP Code
- CAP Color: B=Black C=Milky
- Laser Engraving Pattern: 00=Without
01=Power Symbol
02=Power
03=Reset

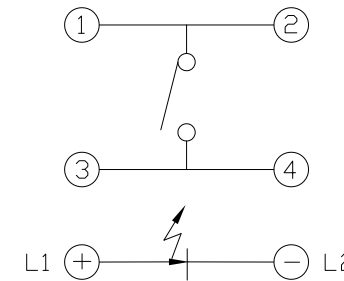

SCHEMATIC

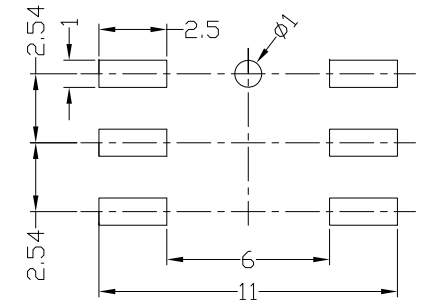

P.C.B LAYOUT

NO.	PARTS	MATERIAL	Q'TY	FINISHING
8				
7				
6	CAP	ABS	1	
5	LED		1	
4	CONTACT	PBS C5210R-EH	1	Ag CLAD
3	TERMINAL	BRASS STRIP	4	Ag PLATED
2	CASE	NYLON+F.G	1	BLACK
1	KNOB	NYLON+F.G	1	NATURAL

WITHIN 1.5mm: ±0.2mm	UNITS mm
OVER 1.5mm: ±0.3mm	MAT'L
	SEE NOTE
	FINISH
	SEE NOTE
	Q'TY

THESE DRAWINGS AND SPECIFICATIONS ARE THE PROPERTY OF ACCURATE INNOTECH INC AND SHALL NOT BE REPRODUCED, COPIED OR USED IN ANY MANNER WITHOUT THE PRIOR WRITTEN CONSENT OF ACCURATE INNOTECH INC.

雅安科技有限公司 ACCURATE INNOTECH INC.			
TITLE: ILLUMINATED TACT SWITCH+CAP		PART NO.: ATI-007-MXX-XXP-000-08PX-XX	
DR: Ricky 2022/05/31		DWG NO.: AZJ-007-M-08P	
CHKD: Ricky 2022/05/31		SCALE: 4:1	SHEET: 1/1
APPD:		REV.: A	CUSTOMER DRAWING



RoHS
Compliant
2002/95/EC

REV.	ECN. NO.	APPD.

MODEL CODE

ATI-007-DW16-**P-01B-08P*-**
1 234 56 78 9 10 11

DIMENSIONS

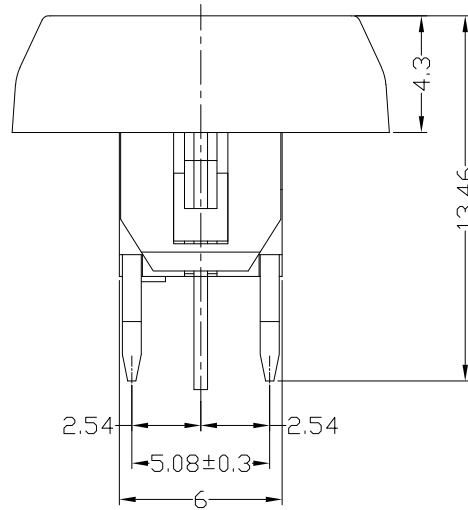
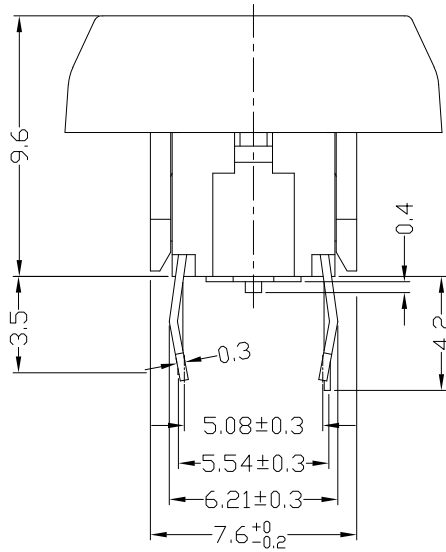
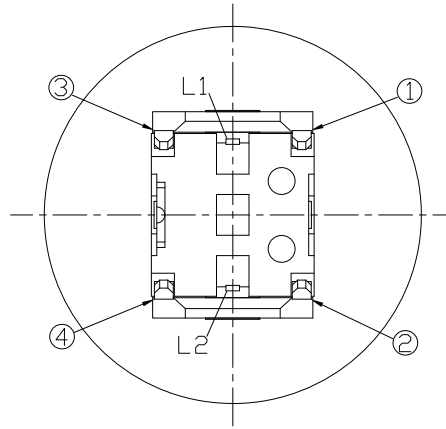
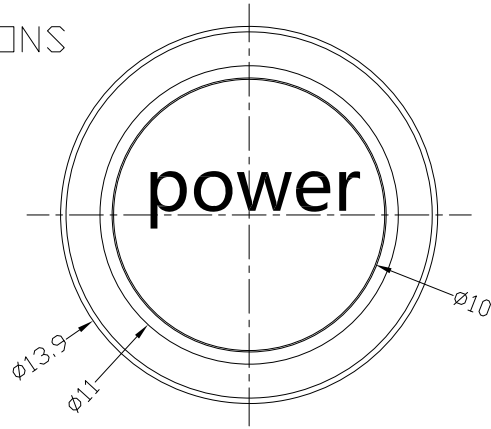

- Series Number
- Terminal Type: D=Dip M=SMT
- Stem Color: W=White B=Black
- Operating Force: 16=160gf 25=250gf
- LED Color: 01=Red 02=Yellow 03=Green
04=Blue 05=White 06=Pure Green
08=Amber 09=Blue Green
0A=Pink 0B=Purple
- LDE Appearance: P=Flat
- HOUSING Code
- HOUSING Color: 0=Without B=Black
- CAP Code
- CAP Color: B=Black C=Milky
- Laser Engraving Pattern: 00=Without
01=Power Symbol
02=Power
03=Reset

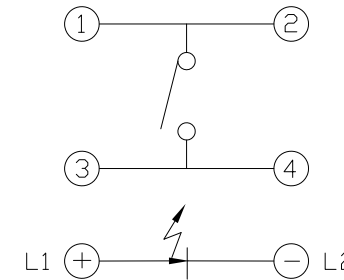

SCHEMATIC

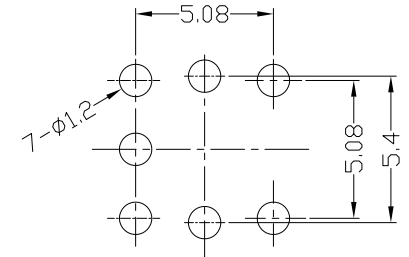

P.C.B LAYOUT

NO.	PARTS	MATERIAL	Q'TY	FINISHING
8				
7	LED		1	
6	CAP SLEEVE	PA66	1	
5	CAP	PC/ABS	1	
4	CONTACT	PBS C5210R-EH	1	Ag CLAD
3	TERMINAL	BRASS STRIP	4	Ag PLATED
2	CASE	NYLON+F.G	1	BLACK
1	KNOB	NYLON+F.G	1	BLACK/WHITE

WITHIN 1.5mm: ±0.2mm	UNITS mm
OVER 1.5mm: ±0.3mm	MAT'L
	SEE NOTE
	FINISH
	SEE NOTE
	Q'TY

雅安科技有限公司 ACCURATE INNOTECH INC.			
TITLE: ILLUMINATED TACT SWITCH+HOUSING+CAP		PART NO.: ATI-007-DXX-XXP-01X-08PX-XX	
DR: Ricky 2022/05/31		DWG NO.: AZJ-007-D-01+08P	
CHKD: Ricky 2022/05/31		SCALE: 4:1	SHEET: 1/1
APPD:		REV.: A	CUSTOMER DRAWING

THESE DRAWINGS AND SPECIFICATIONS ARE THE PROPERTY OF ACCURATE INNOTECH INC AND SHALL NOT BE REPRODUCED, COPIED OR USED IN ANY MANNER WITHOUT THE PRIOR WRITTEN CONSENT OF ACCURATE INNOTECH INC.



RoHS
Compliant
2002/95/EC

REV.	ECN. NO.	APPD.

MODEL CODE

ATI-007-MB16-**P-01B-08P*-**
1 234 56 78 9 10 11

DIMENSIONS

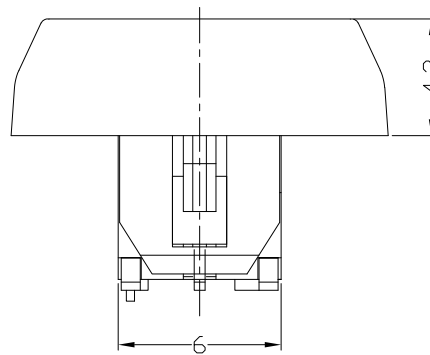
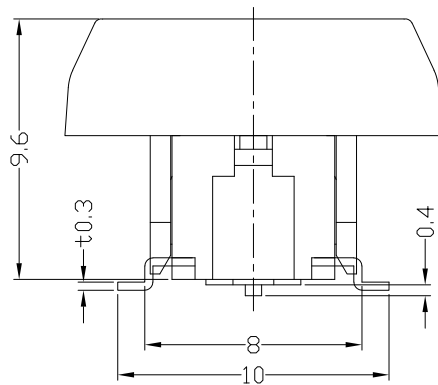
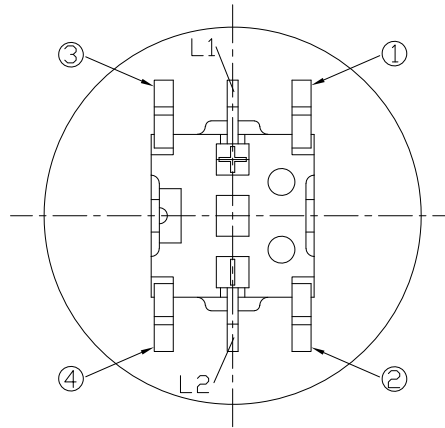
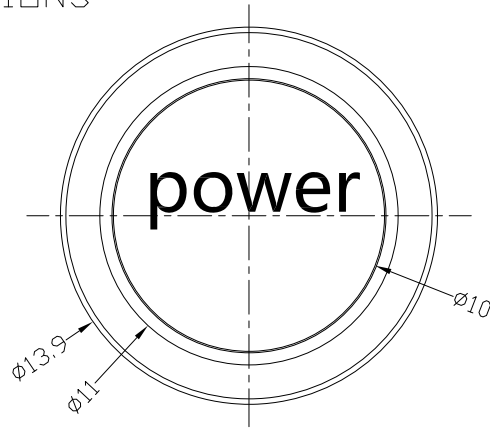

- Series Number
- Terminal Type: D=Dip M=SMT
- Stem Color: W=White B=Black
- Operating Force: 16=160gf 25=250gf
- LED Color: 01=Red 02=Yellow 03=Green
04=Blue 05=White 06=Pure Green
08=Amber 09=Blue Green
0A=Pink 0B=Purple
- LDE Appearance: P=Flat
- HOUSING Code
- HOUSING Color: 0=Without B=Black
- CAP Code
- CAP Color: B=Black C=Milky
- Laser Engraving Pattern: 00=Without
01=Power Symbol
02=Power
03=Reset

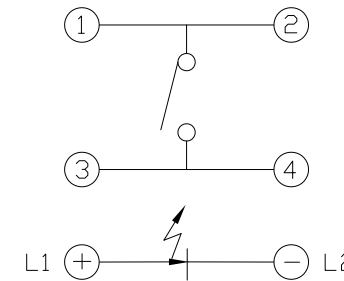

SCHEMATIC

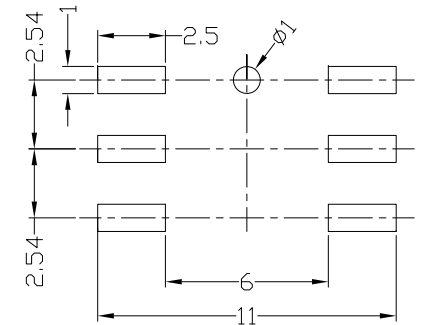

P.C.B LAYOUT

NO.	PARTS	MATERIAL	Q'TY	FINISHING
8				
7	LED		1	
6	CAP SLEEVE	PA66	1	
5	CAP	PC/ABS	1	
4	CONTACT	PBS C5210R-EH	1	Ag CLAD
3	TERMINAL	BRASS STRIP	4	Ag PLATED
2	CASE	NYLON+F.G	1	BLACK
1	KNOB	NYLON+F.G	1	BLACK/WHITE

WITHIN 1.5mm: ±0.2mm	UNITS mm
OVER 1.5mm: ±0.3mm	MAT'L
	SEE NOTE
	FINISH
	SEE NOTE
	Q'TY

雅安科技有限公司 ACCURATE INNOTECH INC.			
TITLE: ILLUMINATED TACT SWITCH+HOUSING+CAP		PART NO.: ATI-007-MXX-XXP-01X-08PX-XX	
DR: <i>Ricky</i> 2022/05/31		DWG NO.: AZJ-007-M-01+08P	
CHKD: <i>Ricky</i> 2022/05/31		SCALE: 4:1	SHEET: 1/1
APPD:		REV.: A	CUSTOMER DRAWING

THESE DRAWINGS AND SPECIFICATIONS ARE THE PROPERTY OF ACCURATE INNOTECH INC AND SHALL NOT BE REPRODUCED, COPIED OR USED IN ANY MANNER WITHOUT THE PRIOR WRITTEN CONSENT OF ACCURATE INNOTECH INC.