

SPECIFICATIONS

CONTACT RATING: Dependent upon contact material See Page 69.

MECHANICAL LIFE: 30,000 make-and-break cycles.

CONTACT RESISTANCE: 20 mΩ max. initial @ 2-4VDC
100mA for both silver and gold plated contacts.

INSULATION RESISTANCE: 1,000 MΩ min.

DIELECTRIC STRENGTH: 1,000 Vrms min. @sea level.

OPERATING TEMPERATURE: -40°C to 85°C.

MATERIALS

CASE: Diallyl phthalate (DAP) (UL94v-0).

ACTUATOR: Nylon, black std.

BUSHING: Brass or Zinc, nickel plated.

HOUSING: Stainless Steel.

SWITCH SUPPORT: SUS or Brass, tin plated.

TERMINAL/CONTACT: Copper alloy or Brass, with silver or gold plated. (See Page 69)



4M
Rocker Switches

HOW TO ORDER

MODEL NO. ACTUATOR ACTUATOR COLOR ACTUATOR MARKING TERMINATIONS TERMINAL PLATING SEAL RoHS SOLDERING

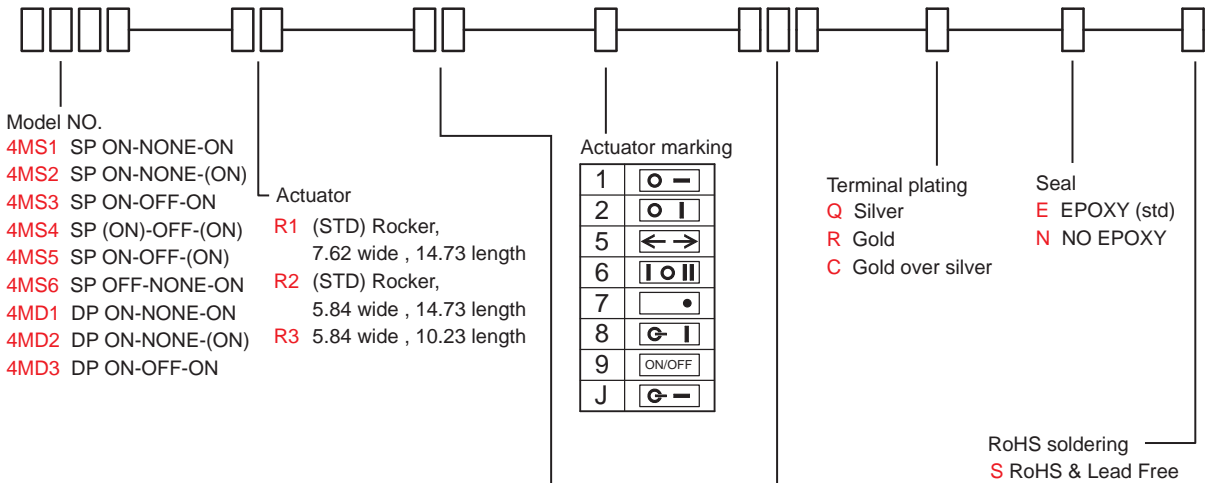

- Model NO.
- 4MS1 SP ON-NONE-ON
 - 4MS2 SP ON-NONE-(ON)
 - 4MS3 SP ON-OFF-ON
 - 4MS4 SP (ON)-OFF-(ON)
 - 4MS5 SP ON-OFF-(ON)
 - 4MS6 SP OFF-NONE-ON
 - 4MD1 DP ON-NONE-ON
 - 4MD2 DP ON-NONE-(ON)
 - 4MD3 DP ON-OFF-ON

- Actuator
- R1 (STD) Rocker, 7.62 wide , 14.73 length
 - R2 (STD) Rocker, 5.84 wide , 14.73 length
 - R3 5.84 wide , 10.23 length

Actuator marking

1	○ —
2	○
5	← →
6	○
7	— •
8	⊕
9	ON/OFF
J	⊕ —

- Terminal plating
- Q Silver
 - R Gold
 - C Gold over silver
- Seal
- E EPOXY (std)
 - N NO EPOXY

- RoHS soldering
- S RoHS & Lead Free

Actuator color

ITEM NO	COLOR
01	White
02	Black (Std)
03	Red
04	Orange
05	Yellow
06	Green
07	Blue
08	Brown
09	Gray

* Besides standard color, other colors need to check stocks available.

- Terminations
- M1 Solder Lug
 - M2 PC thru-hole
 - M5 wire wrap
 - M6 Right angle, PC thru-hole
 - M6N Right angle, snap-in, PC thru-hole
 - M7 Vertical right angle, PC thru-hole
 - M7N Vertical right angle, snap-in, PC thru-hole
 - VS2 8.94 high, V-bracket
 - V2N 8.94 high, snap-in V-bracket
 - VS3 8.94 high, V-bracket
 - V3N 8.94 high, snap-in V-bracket

* 4MS6 model type not applicable to M6/M6N/M7/M7N terminations

4M Series

Sub-Miniature Rocker Switches

SWITCH FUNCTION

NO. POLES	UL/CSA MODEL NO.	MODEL NO.	SWITCH FUNCTION			CONNECTED TERMINALS / SCHEMATIC		
			POS.1	POS.2	POS.3	POS.1	POS.2	POS.3
SP	Q2411	4MS1	ON	NONE	ON	2-3	N/A	2-1
	Q2412	4MS2	ON	NONE	(ON)			
	Q2413	4MS3	ON	OFF	ON		OPEN	
	Q2414	4MS4	(ON)	OFF	(ON)			
	Q2415	4MS5	ON	OFF	(ON)	OPEN	N/A	3-1
	Q2416	4MS6	OFF	NONE	ON			
DP	Q2421	4MD1	ON	NONE	ON	2-3,5-6	N/A	2-1,5-4
	Q2422	4MD2	ON	NONE	(ON)			
	Q2423	4MD3	ON	OFF	ON		OPEN	

()=MOMENTARY

POLE OPTIONS

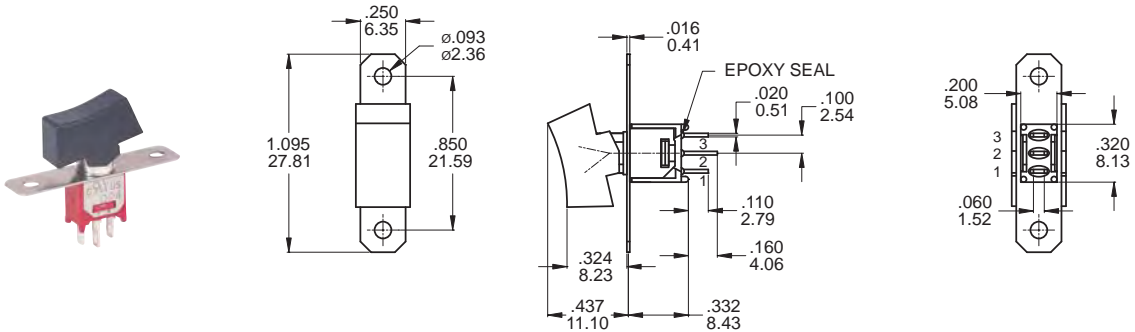

SPDT

Part No. Shown : 4MS1R102M1QES

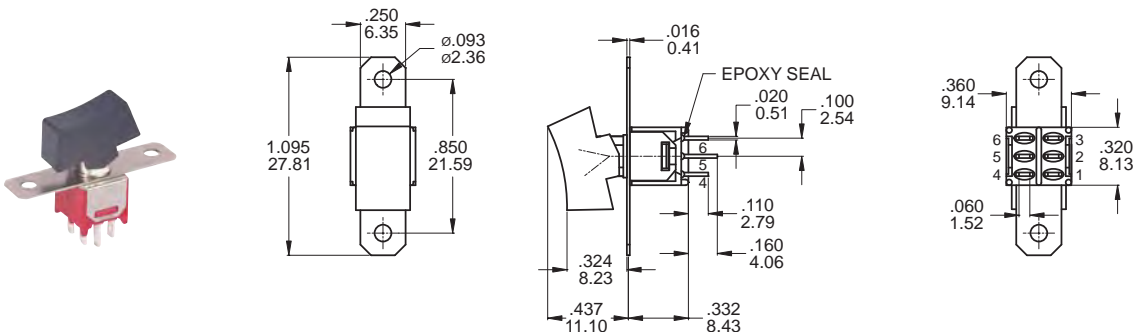

DPDT

Part No. Shown : 4MD1R102M1QES

ACTUATOR OPTIONS - PANEL MOUNT

R1

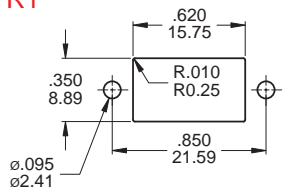

PANEL MOUNTING-R1

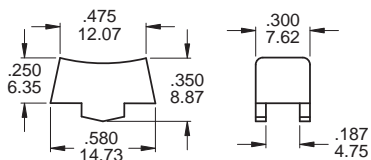

R2

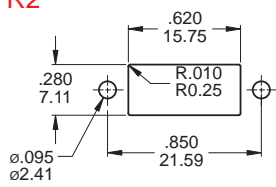

PANEL MOUNTING-R2

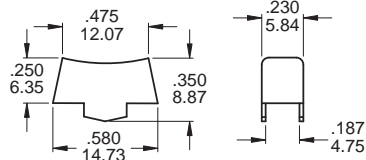

R3

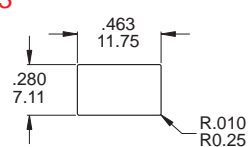

PANEL MOUNTING-R3

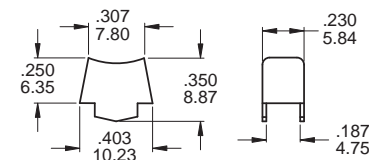

4M
Rocker Switches

TERMINATION OPTIONS

M1 Solder lug

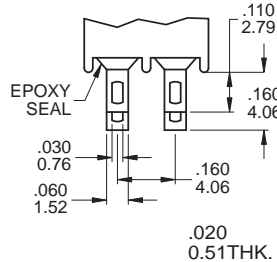
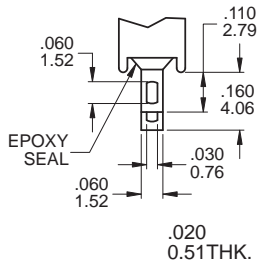

Double Pole

M2 PC Thru-hole

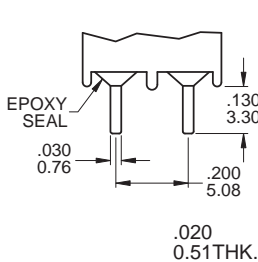
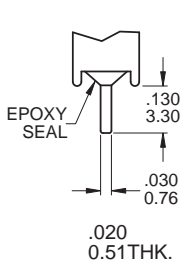

Double Pole

M5 Wire Wrap

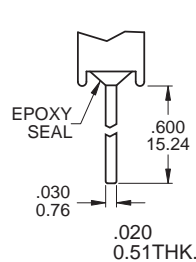

M6

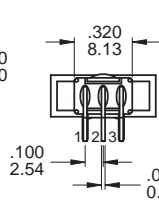
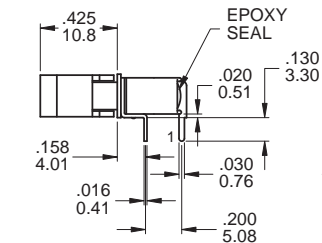
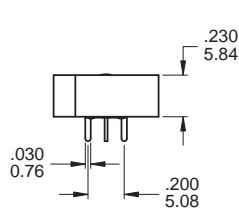

P.C. MOUNTING

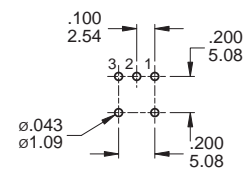

SPDT

Part No. Shown : 4MS1R202M6QES

M6

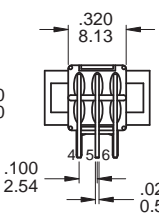
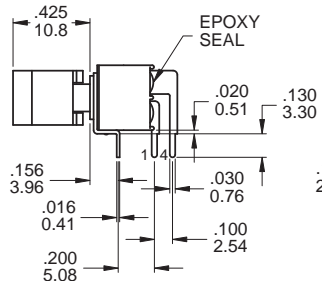
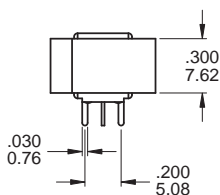

P.C. MOUNTING

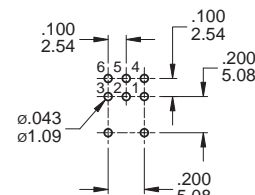

DPDT

Part No. Shown : 4MD1R102M6QES

4M Series

Sub-Miniature Rocker Switches

M7

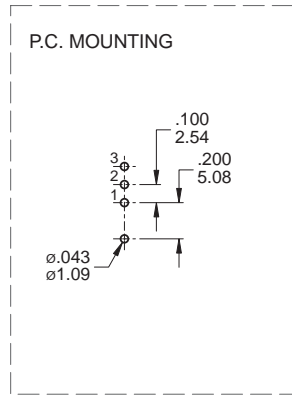
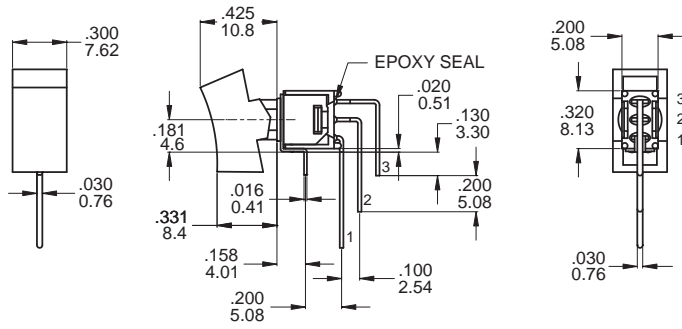

SPDT

Part No. Shown : 4MS1R102M7QES

M7

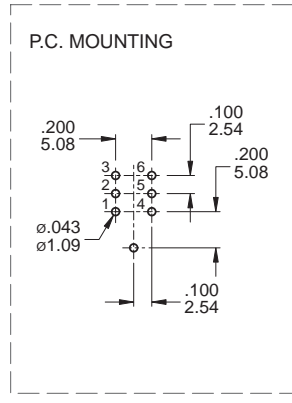
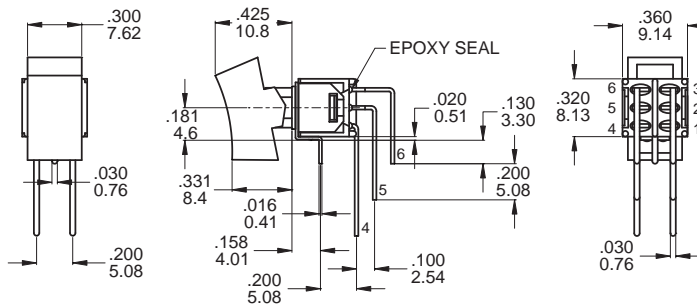

DPDT

Part No. Shown : 4MD1R102M7QES

VS2 - VS3

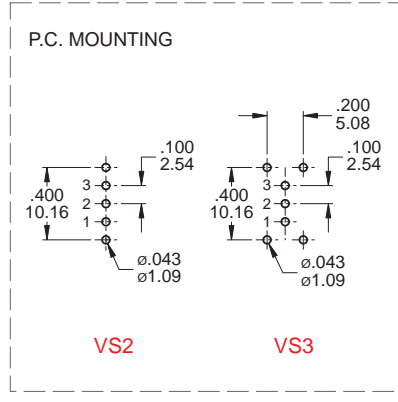
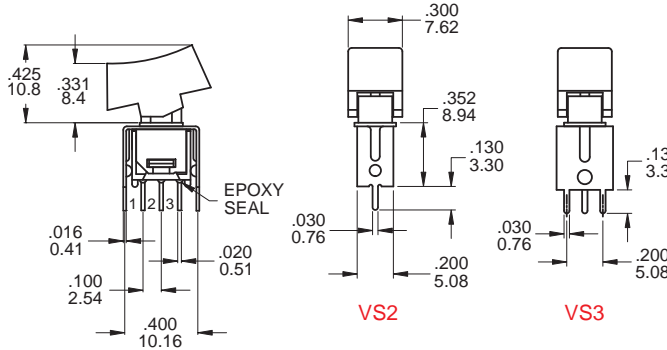

SPDT

Part No. Shown : 4MS1R102VS2QES

VS2 - VS3

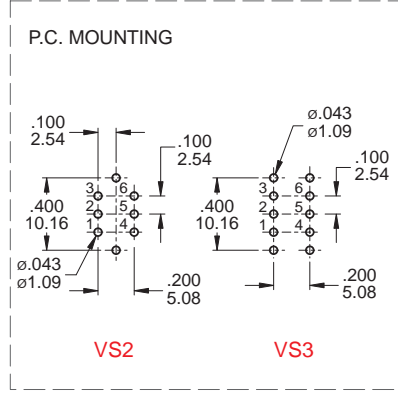
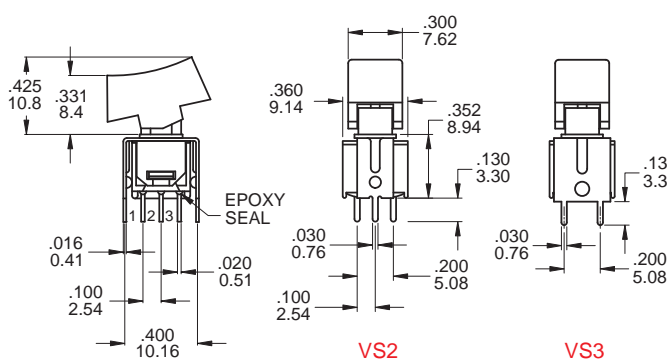

DPDT

Part No. Shown : 4MD1R102VS2QES

4M
Rocker Switches

SNAP-IN TERMINATION OPTIONS

M6N



M7N

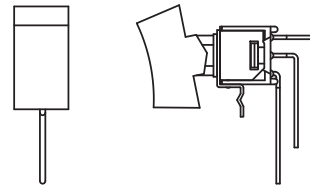

V2N

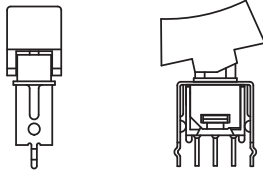

V3N

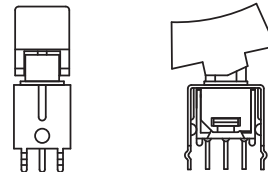

CONTACT MATERIAL OPTIONS

	CONTACT PLATING	TERMINAL PLATING	RATINGS
Q	Silver	Silver	3 Amps with resistant load @ 120VAC or 28VDC
C	Gold over Silver	Gold over silver	1 Amps with resistant load @ 250VAC
R	Gold	Gold	0.4 Volt - Amps (VA) max. @ 20V max. (AC or DC)

SOLDERING PROCESSES

MANUAL SOLDERING: Use soldering iron of 30 watts, controlled at 350°C approximately 5 seconds while applying solder.

WAVE SOLDERING: Recommended Soldering Temperature: 270 ± 5°C
Duration of Solder Immersion: Max 5 sec. (PCB is 1.6mm in thickness)



4M
Rocker Switches