

7M Series

Snap-Acting Pushbutton Switches

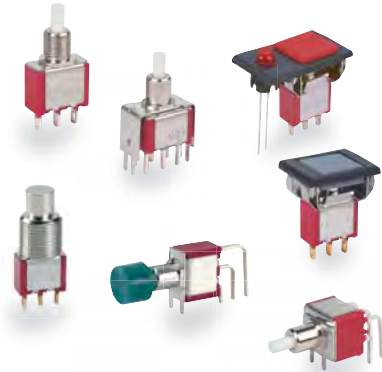

SPECIFICATIONS

CONTACT RATING: Dependent upon contact material
see page 107.

MECHANICAL LIFE: 50,000 make-and-break cycles.

CONTACT RESISTANCE: 20mΩ max. initial @ 2-4VDC
100mA for both silver and gold plated contacts.

INSULATION RESISTANCE: 1,000MΩ min.

DIELECTRIC STRENGTH: 1,000 Vrms min. @ sea level.

OPERATING TEMPERATURE: -40°C to 85°C.

MATERIALS

CASE: Diallyl phthalate(DAP) (UL94V-0).

PLUNGER: Glass filled Nylon or Glass filled polyester.(PBT)

BUSHING: Brass,nickel plated.

HOUSING: Stainless Steel.

CONTACT: Brass or Copper alloy, silver or gold plated.

※7MSL/7MDL with gold over silver for plating
(See Page 107)

HOW TO ORDER

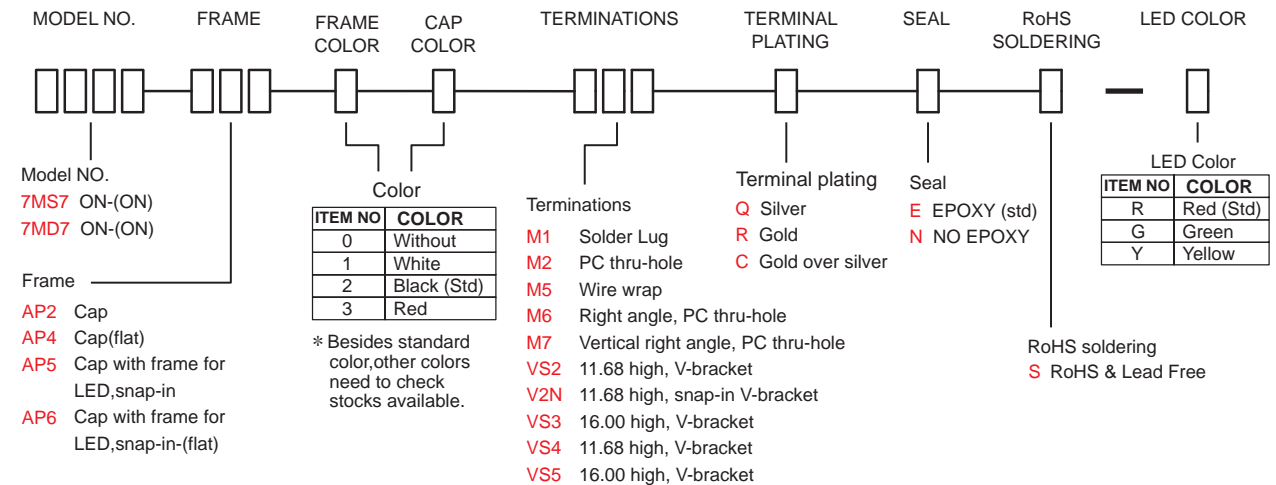
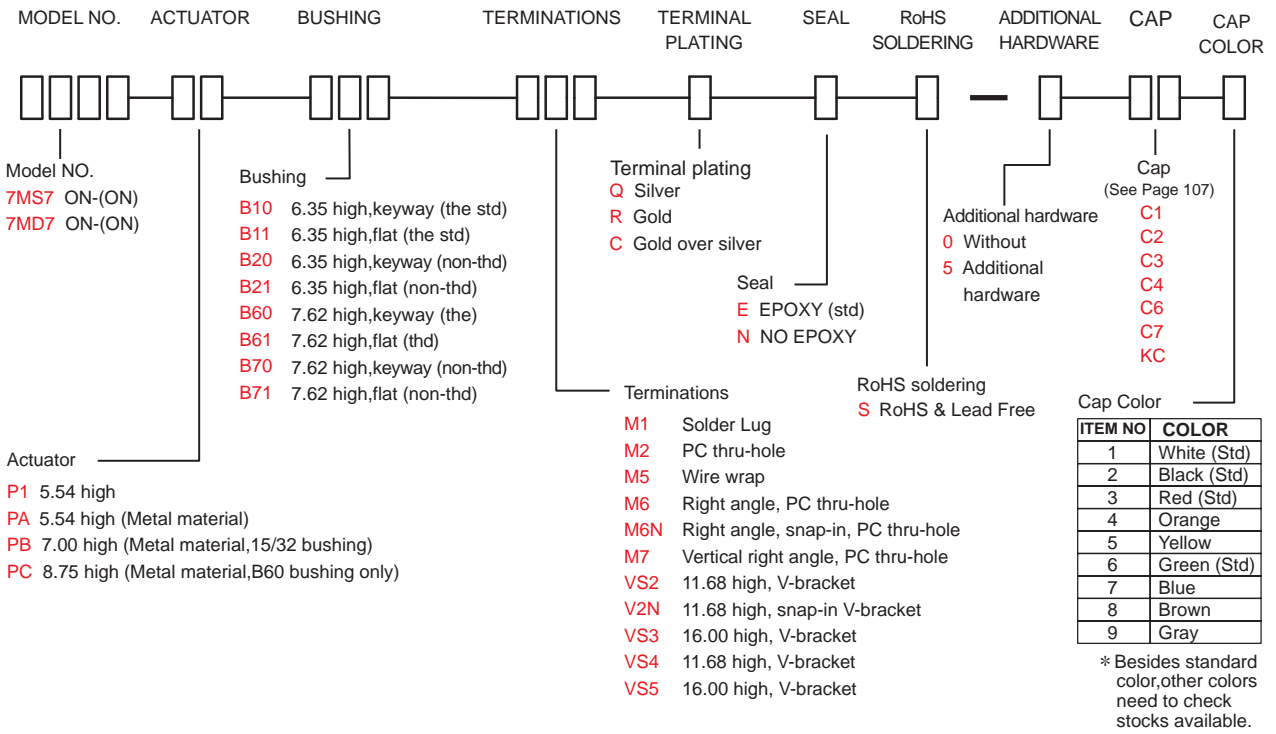

SWITCH FUNCTION

NO. POLES	UL/CSA MODEL NO.	MODEL NO.	SWITCH FUNCTION		CONNECTED TERMINALS / SCHEMATIC	
			POS.1	POS.2	POS.1	POS.2
SP	Q2717	7MS7	ON	(ON)	1-3 	1-2
DP	Q2727	7MD7	ON	(ON)	1-3,4-6 	1-2,4-5

() = MOMENTARY

POLE OPTIONS

M1

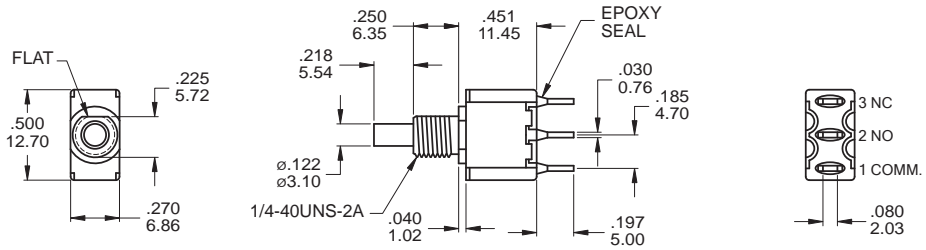

SPDT

Part No. Shown : 7MS7P1B11M1QES

M1

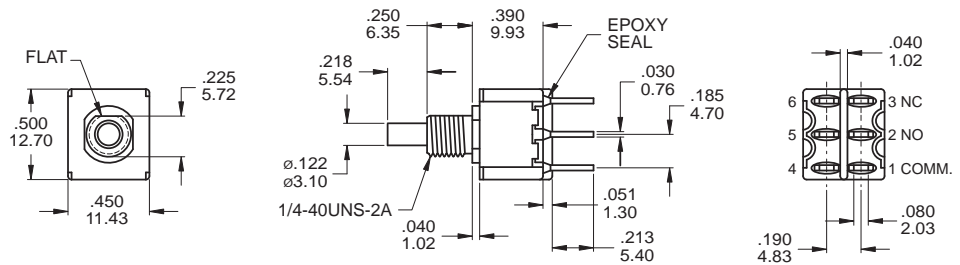

DPDT

Part No. Shown : 7MD7P1B11M1QES

M2

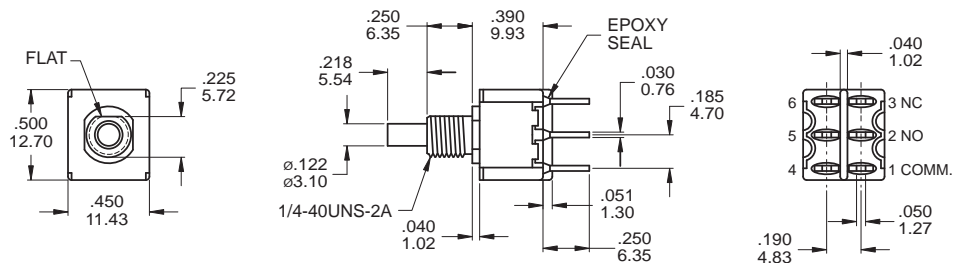

DPDT

Part No. Shown : 7MD7P1B11M2RES



7M Series

Snap-Acting Pushbutton Switches

ACTUATOR OPTIONS

P1

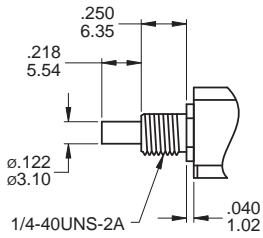

PAB60 handle, metal material

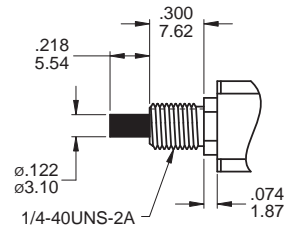

PBB13 handle, metal material

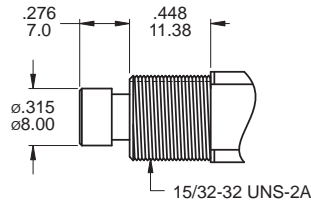

PCB60 handle, metal material

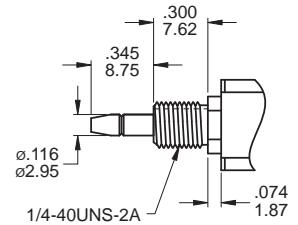

Use with B13 bushing only

Use with B60 bushing std
* PC Actuator only for KC Cap

BUSHING OPTIONS

B10 THD STD
B20 NON-THD

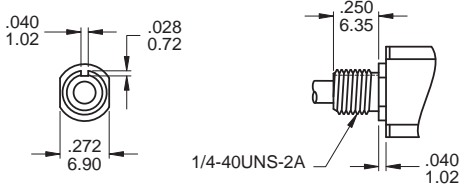

B11 THD STD
B21 NON-THD

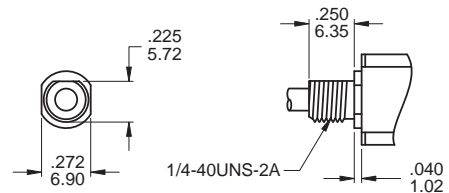

B60 THD
B70 NON-THD

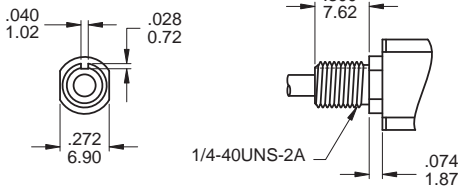

B61 THD
B71 NON-THD

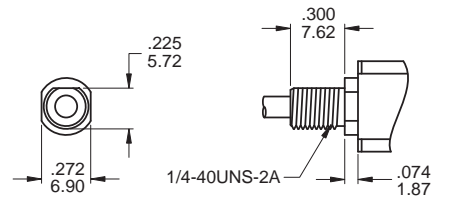

TERMINATION OPTIONS

M1 Solder lug

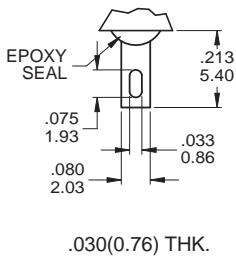

M2 PC Thru-hole

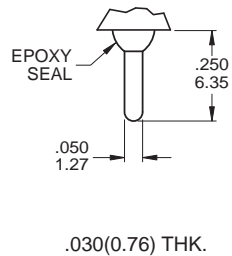

M3 Quick connect

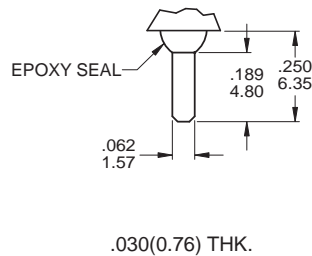

M5 Wire Wrap

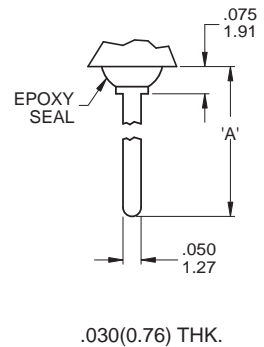

OTHER TERMINATION OPTIONS

- M6** Right angle P.C. Mount
- M7** Right angle P.C. Mount
- VS2** Vertical bracket P.C. Mount
- VS3** Vertical bracket P.C. Mount
- VS4** Vertical bracket P.C. Mount
- VS5** Vertical bracket P.C. Mount

- M6N** Right angle P.C. Mount Snap-in bracket
- V2N** Vertical bracket P.C. Mount Snap-in bracket

OPTION CODE	DIM. 'A'
M51	.750 (19.50)
M52	.964 (24.48)
M53	.426 (10.80)
M54	.650 (16.50)

M6

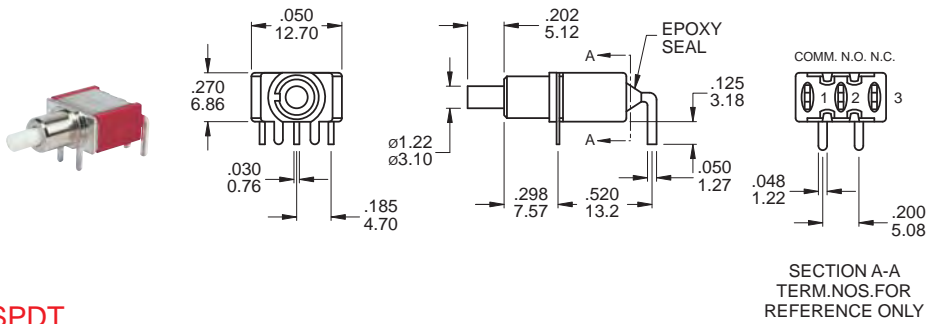

P.C. MOUNTING

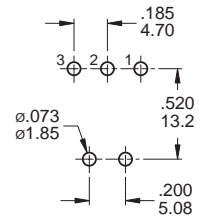

SPDT

Part No. Shown : 7MS7P1B20M6QES

M6

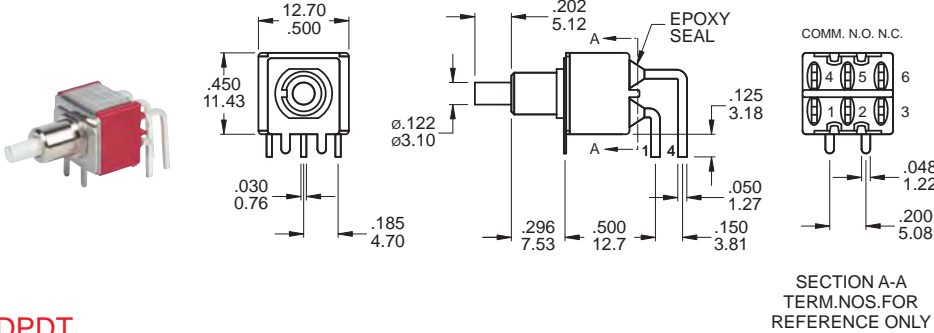

P.C. MOUNTING

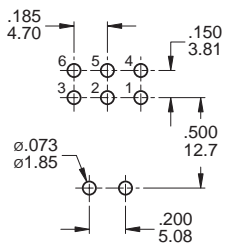

DPDT

Part No. Shown : 7MD7P1B20M6QES

M7

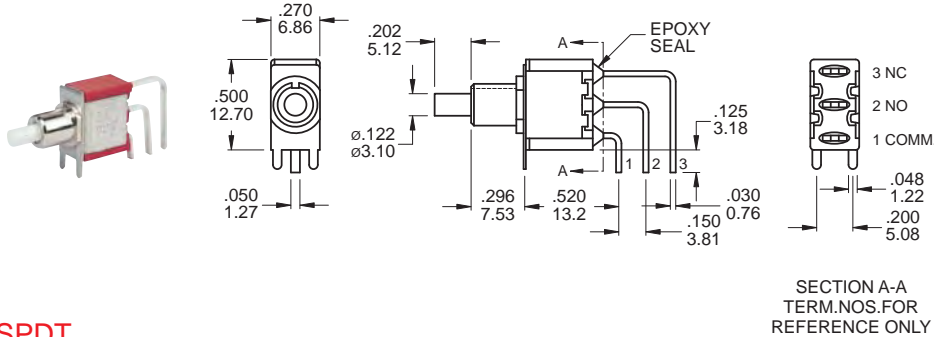

P.C. MOUNTING

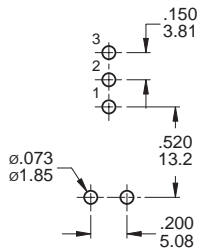

SPDT

Part No. Shown : 7MS7P1B20M7QES

M7

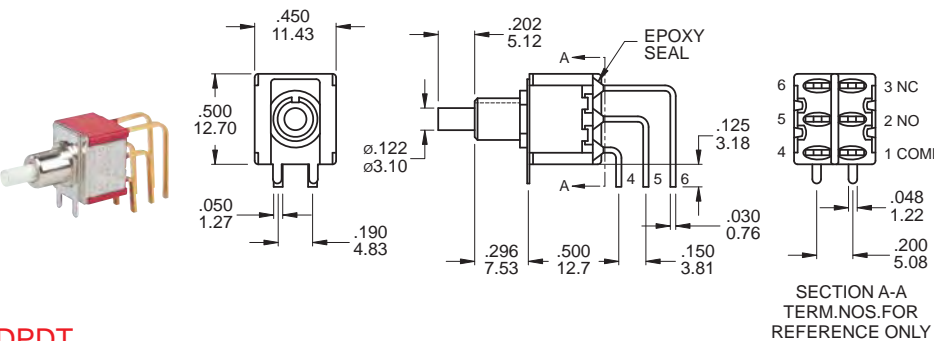

P.C. MOUNTING

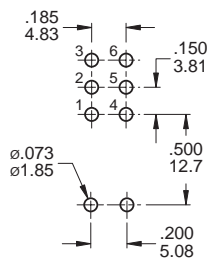

DPDT

Part No. Shown : 7MD7P1B20M7RES



SNAP-IN TERMINATION OPTIONS

M6N

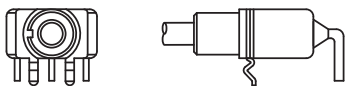

V2N

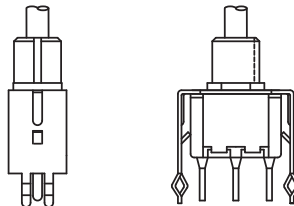

PANEL MOUNTING

AP2 CAP & FRAME

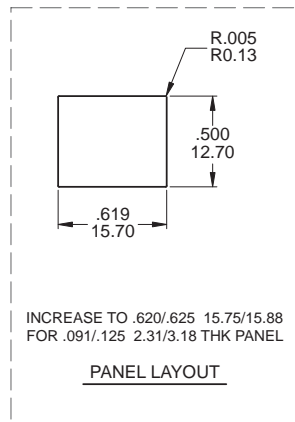
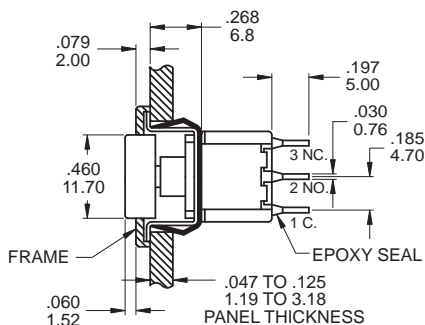
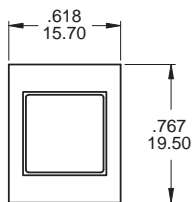

SPDT

Part No. Shown : 7MS7AP223M1QES

AP2 CAP & FRAME

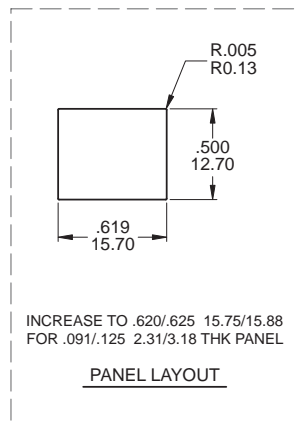
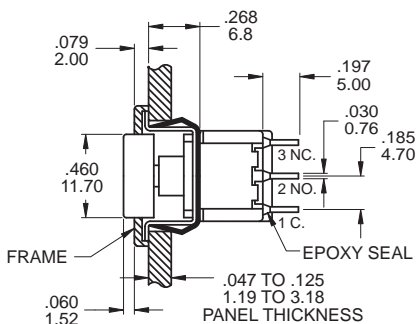
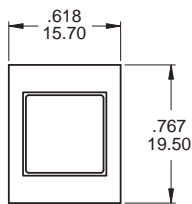

DPDT

Part No. Shown : 7MD7AP223M1QES

AP4 CAP & FRAME

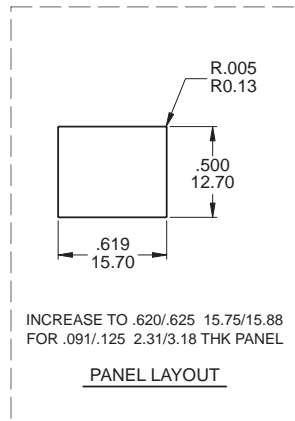
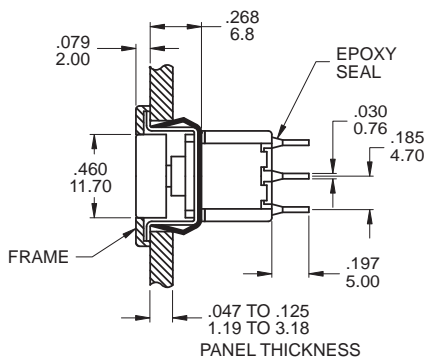
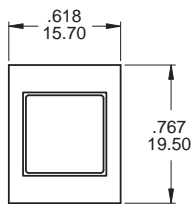

SPDT

Part No. Shown : 7MS7AP429M1RES



7M Pushbutton Switches

7M Series

Snap-Acting Pushbutton Switches

PANEL MOUNTING

AP4 CAP & FRAME

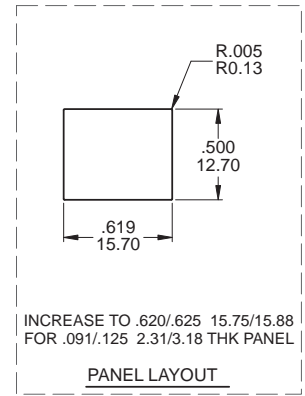
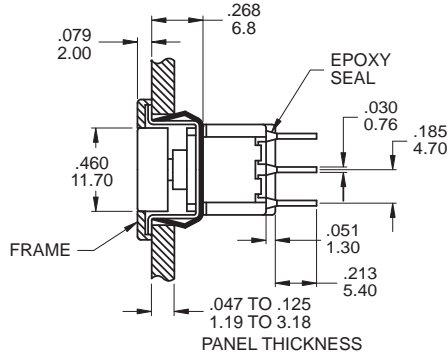
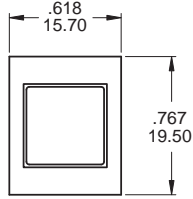

DPDT

Part No. Shown : 7MD7AP423M1RES

AP5 CAP & FRAME

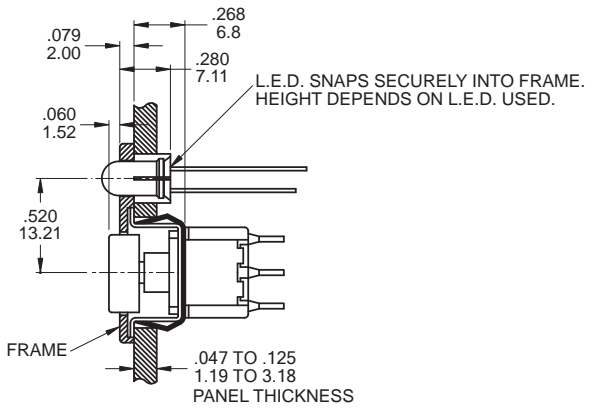
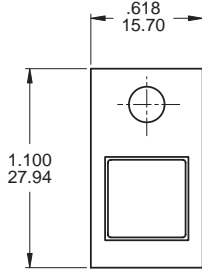
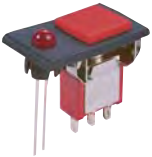

SPDT

Part No. Shown : 7MS7AP523M1QES

AP6 CAP & FRAME

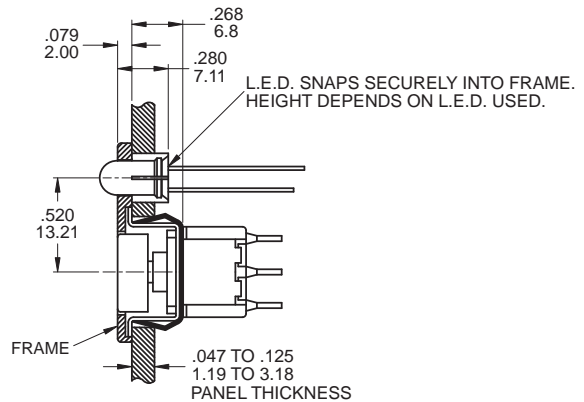
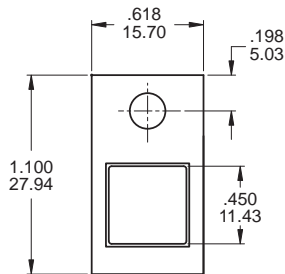

SPDT

Part No. Shown : 7MS7AP629M1RES

FOR AP5/AP6

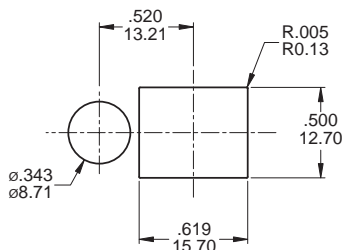

PANEL LAYOUT

CAP AND FRAME COLORS

OPTION CODE	COLOR
1	WHITE
2	BLACK(std)
3	RED

LED COLORS

OPTION CODE	COLOR
R	RED(std)
G	GREEN
Y	YELLOW

* Besides standard color, other colors need to check stocks available.