

IP 67
ACCORDING TO
EN 60529:1991+A1:2001
IEC 60529:2001

UL US
E 187490

RoHS
compliant

Pb
lead-free

SPECIFICATIONS

CONTACT RATING: Dependent upon contact material See Page 125.

MECHANICAL LIFE: 50,000 make-and-break cycles.

CONTACT RESISTANCE: 20 mΩ max. initial @ 2-4VDC

100mA for both silver and gold plated contacts.

INSULATION RESISTANCE: 1,000 MΩ min.

DIELECTRIC STRENGTH: 1,000 Vrms min. @sea level.

OPERATING TEMPERATURE: -40°C to 85°C.

MATERIALS

CASE & BUSHING: Glass filled nylon 6/6, flame retardand, heat stabilized (UL94V-0).

PLUNGER: Thermoplastic Polyester (UL 94V-0), with internal O-ring seal.

SWITCH SUPPORT: Brass or steel electrotin plated.

CONTACT: Copper alloy,with silver or gold plated.

(See Page 125)

HOW TO ORDER

MODEL NO. ACTUATOR BUSHING TERMINATIONS TERMINAL PLATING SEAL RoHS SOLDERING CAPS CAP COLOR
See below

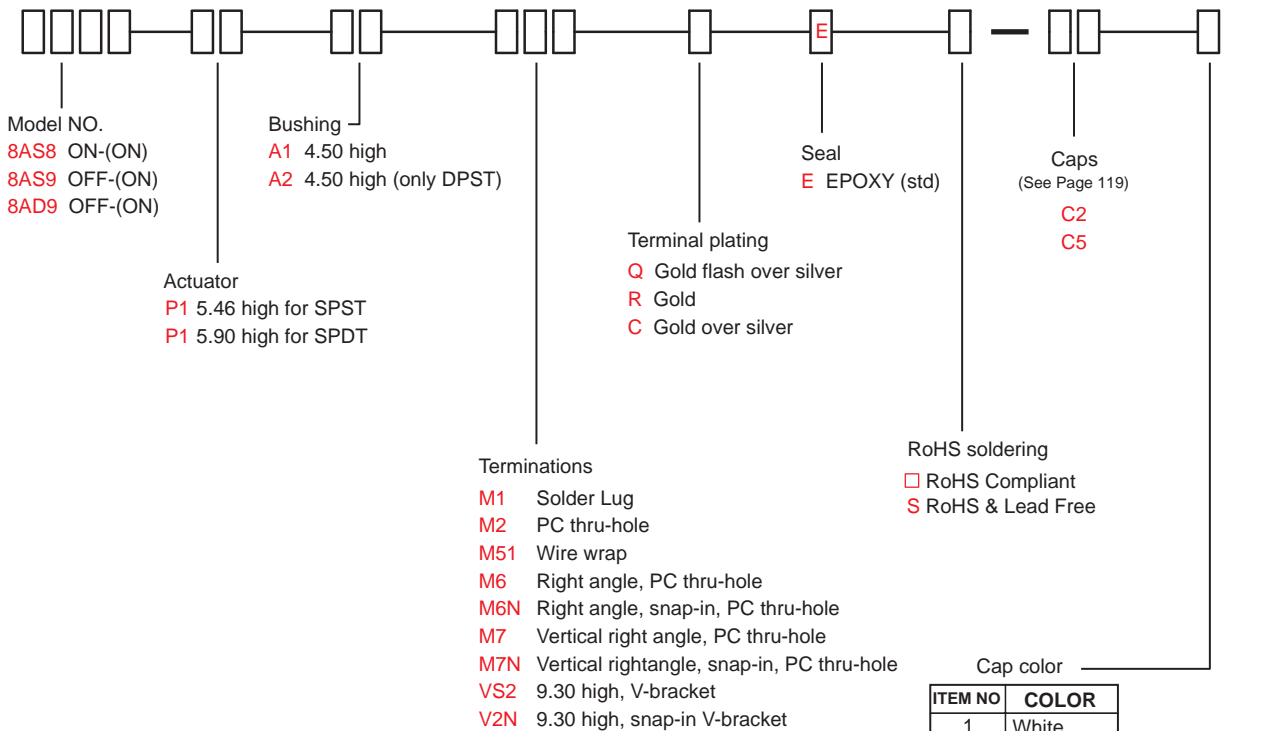







* Besides standard color, other colors need to check stocks available.

8A Series

Sealed Sub-Miniature Pushbutton Switches

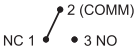
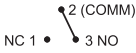
SWITCH FUNCTION

NO. POLES	UL/CSA MODEL NO.	MODEL NO.	SWITCH FUNCTION		CONNECTED TERMINALS / SCHEMATIC	
			POS.1	POS.2	POS.1	POS.2
						
SP	Q28A18	8AS8	ON	(ON)	2-1 	2-3 
	Q28A19	8AS9	OFF	(ON)	OPEN	1-3 
DP	Q28A29	8AD9	OFF	(ON)	OPEN	1-3,4-6 

()=MOMENTARY

POLE OPTIONS

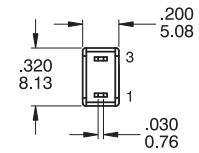
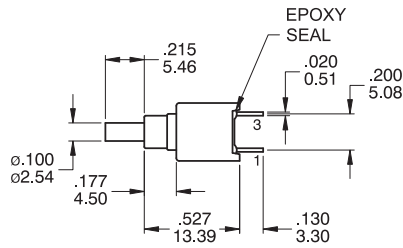
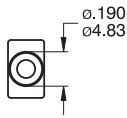

SPST

Part No. Shown : 8AS9P1A1M2RE

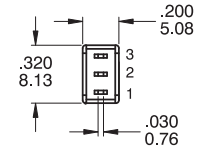
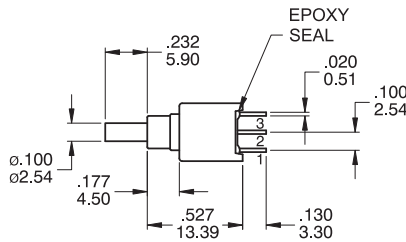
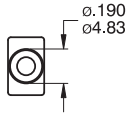

SPDT

Part No. Shown : 8AS8P1A1M2RE

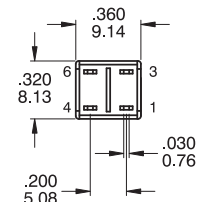
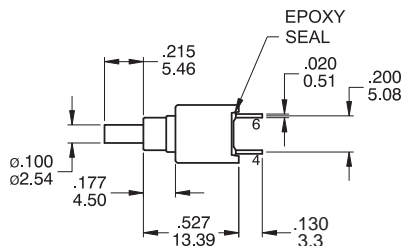
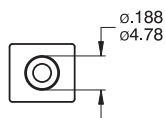

DPST

Part No. Shown : 8AD9P1A2M2RE

TERMINATION OPTIONS

M1 Solder lug

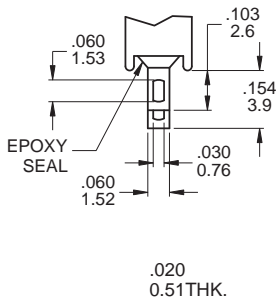

M2 PC Thru-hole

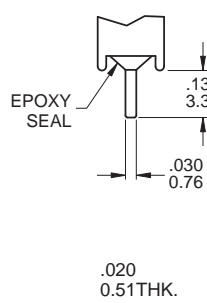

M51 Wire Wrap

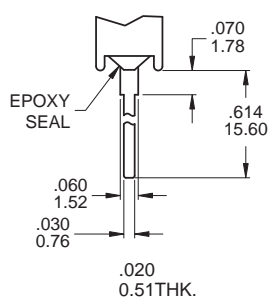

OTHER TERMINATION OPTIONS

- M6** Right angle P.C. Mount
- M6N** Right angle P.C. Mount With snap-in bracket
- M7** Right angle P.C. Mount
- M7N** Right angle P.C. Mount With snap-in bracket
- VS2** Vertical bracket P.C. Mount
- V2N** Vertical bracket P.C. Mount With snap-in bracket

M6

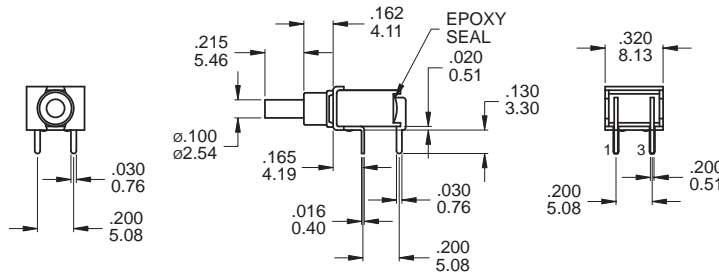

P.C. MOUNTING

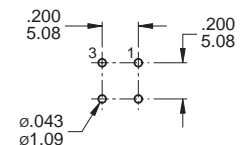

SPST

Part No. Shown : 8AS9P1A1M6RE

M6

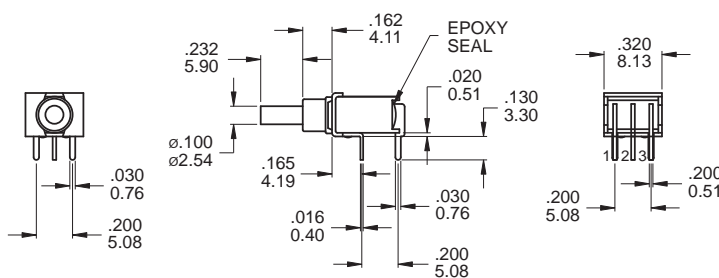

P.C. MOUNTING

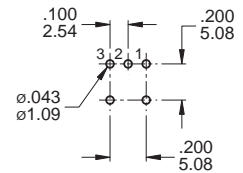

SPDT

Part No. Shown : 8AS8P1A1M6RE

M6

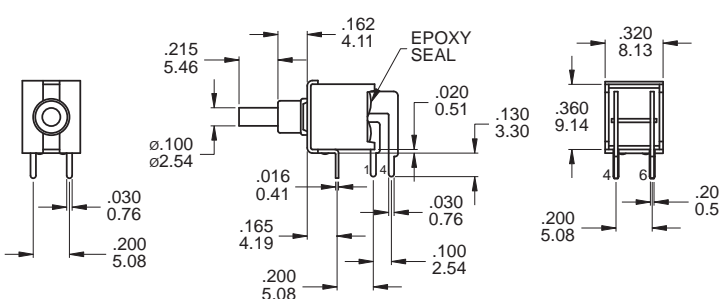

P.C. MOUNTING

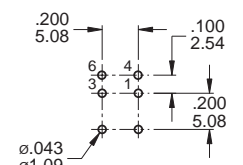

DPST

Part No. Shown : 8AD9P1A2M6RE



8A Series

Sealed Sub-Miniature Pushbutton Switches

M7

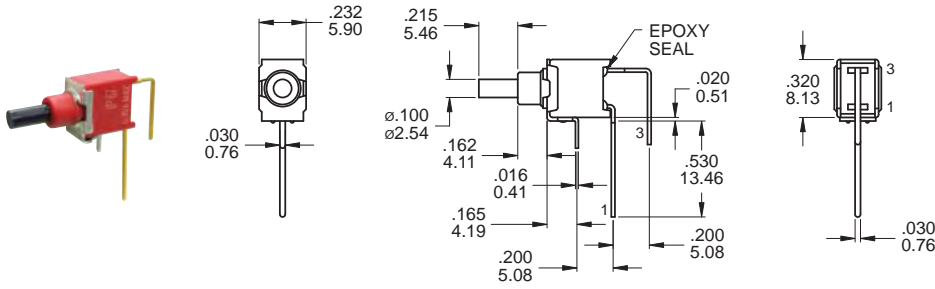

P.C. MOUNTING

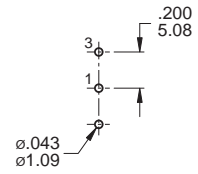

SPST

Part No. Shown : 8AS9P1A1M7RE

M7

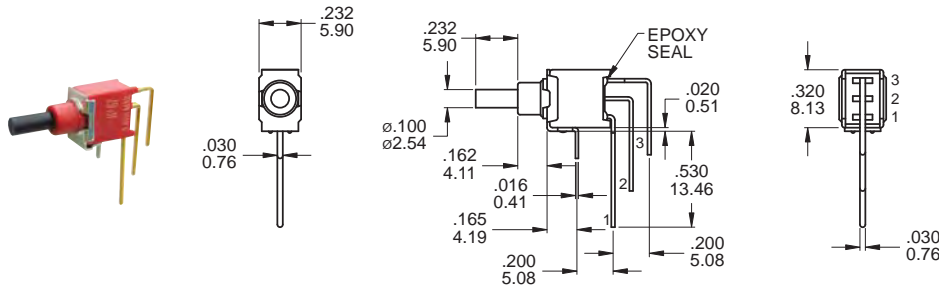

P.C. MOUNTING

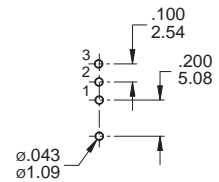

SPDT

Part No. Shown : 8AS8P1A1M7RE

M7

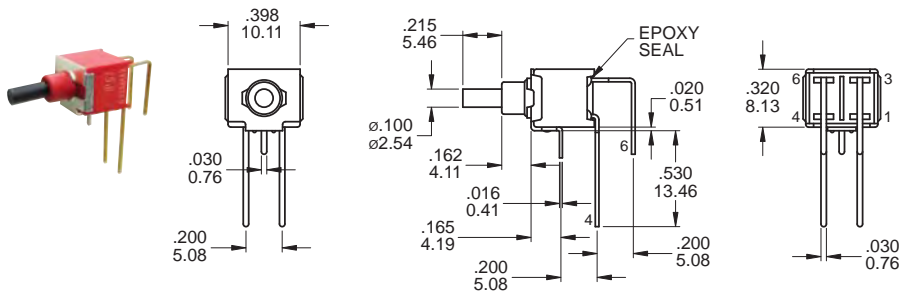

P.C. MOUNTING

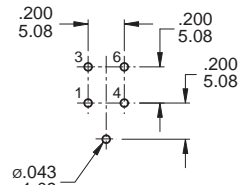

DPST

Part No. Shown : 8AD9P1A2M7RE

VS2

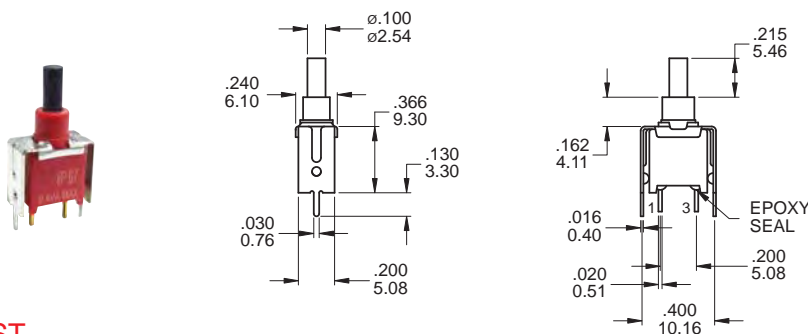

P.C. MOUNTING

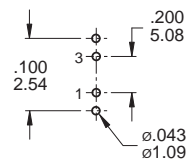

SPST

Part No. Shown : 8AS9P1A1VS2RE

VS2

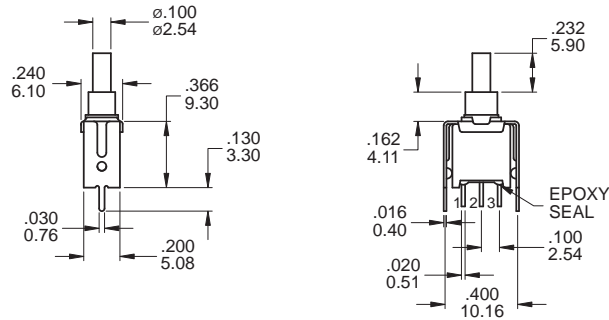

P.C. MOUNTING

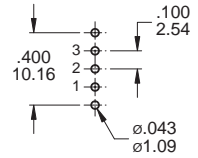

SPDT

Part No. Shown : 8AS8P1A1VS2RE

VS2

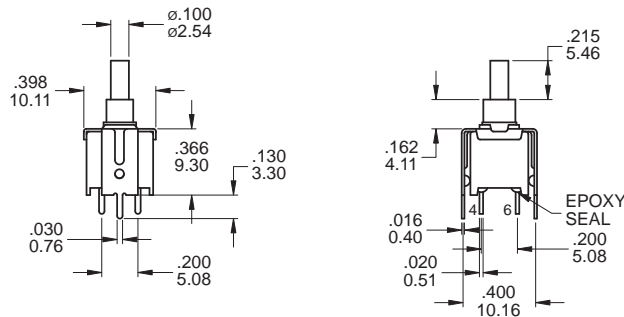

P.C. MOUNTING

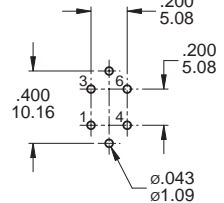

DPST

Part No. Shown : 8AD9P1A2VS2RE

CONTACT MATERIAL OPTIONS

	CONTACT PLATING	TERMINAL PLATING	RATINGS
Q	Silver	Gold flash over silver	3 Amps with resistant load @ 120VAC or 28VDC 1 Amps with resistant load @ 250VAC
C	Gold over Silver	Gold over silver	
R	Gold	Gold	0.4 Volt - Amps (VA) max. @ 20V max. (AC or DC)

SOLDERING PROCESSES

MANUAL SOLDERING: Use soldering iron of 30 watts, controlled at 350°C approximately 5 seconds while applying solder.

WAVE SOLDERING: Recommended Soldering Temperature: 270 ± 5°C
Duration of Solder Immersion: Max 5 sec. (PCB is 1.6mm in thickness)

