

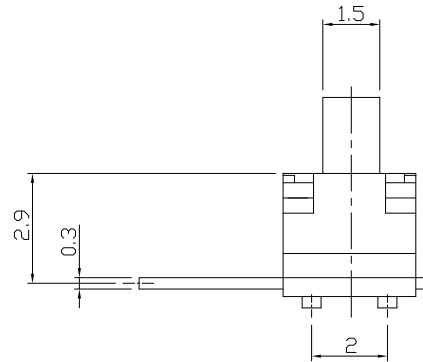

RoHS Compliant
2002/95/EC

REV.	ECN.	NO.	APPD.

DIMENSIONS

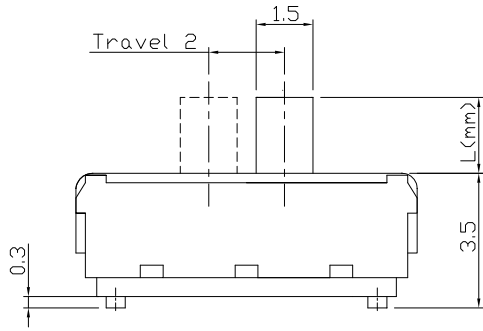

CIRCUIT DIAGRAM

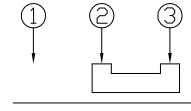

PRODUCT IMAGE

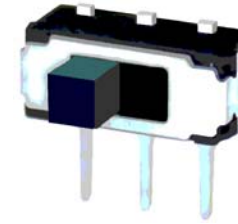

MODEL CODE

AS-1260N - B

L (mm)	Knob Color
- 2.0	B Black
A 4.0	
B 3.0	

P.C.B MOUNTING PATTERN DIMENSION

The following soldering patterns are recommended for reflow soldering

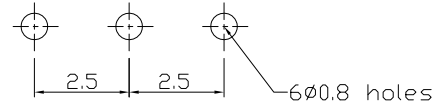
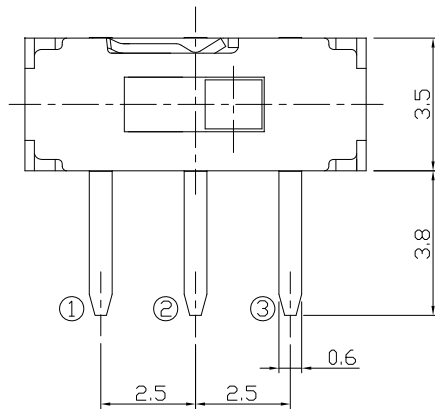

ELECTRO-MECHANICAL CHARACTERISTICS

Refer to additional specifications

Rating	DC 6V 0.3A
Circuit	1C-2P
Contact Resistance	70m Ω Max.
Travel	2.0 \pm 0.3mm
Operating Force	200 \pm 100gf
Operating Life(cycles)	10,000

.X \pm 0.2 X. \pm 2'

UNITS mm

MAT'L

SEE NOTE

FINISH

SEE NOTE

Q'TY

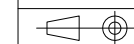

THESE DRAWINGS AND SPECIFICATIONS ARE THE PROPERTY OF ACCURATE INNOTECH INC AND SHALL NOT BE REPRODUCED, COPIED OR USED IN ANY MANNER WITHOUT THE PRIOR WRITTEN CONSENT OF ACCURATE INNOTECH INC.

雅安科技有限公司
ACCURATE INNOTECH INC.

TITLE: MINI SLIDE SWITCH

DR: *Ricky* 2024/03/22

CHKD: *Ricky* 2024/03/22

APPD:

PART NO.: AS-1260N SERIES

DWG NO.: ASI-1260N

SCALE SHEET REV. CUSTOMER DRAWING

1:1 1/1 A

1:1 1/1 A

1:1 1/1 A