

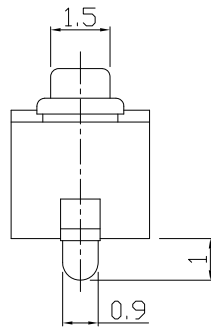

RoHS
Compliant
2002/95/EC

REV.	ECN.	NO.	APPD.

DIMENSIONS

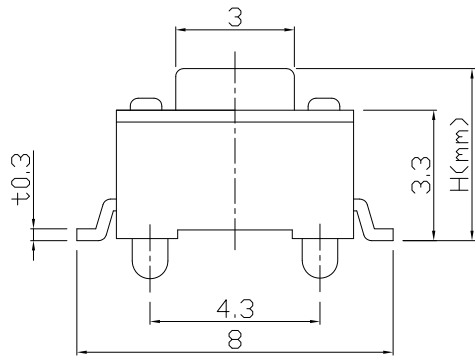

CIRCUIT DIAGRAM

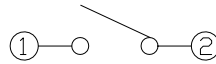

PRODUCT IMAGE



MODEL CODE

AT-1101E-

	H
-	4.3
A	5.0

P.C.B MOUNTING PATTERN DIMENSION

The following soldering patterns are recommended for reflow soldering

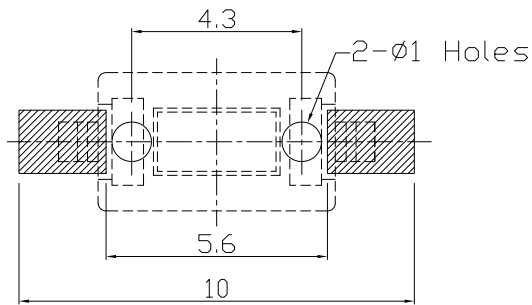
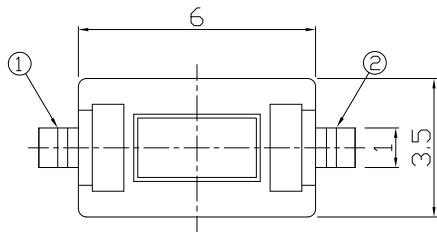

ELECTRO-MECHANICAL CHARACTERISTICS

Refer to additional specifications

Rating	DC 12V 50mA		
Contact Resistance	100mΩ Max.		
Travel	0.25 ± 0.1mm		
Operating Force	160,180±30gf	250±50gf	520±100gf
Operating Life(cycles)	50,000	30,000	10,000

.X ±0.2

X. ±2'

UNITS mm

MAT'L

SEE NOTE

FINISH

SEE NOTE

Q'TY

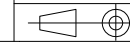

雅安科技有限公司
ACCURATE INNOTECH INC.

TITLE:
TACT SWITCH

PART NO.:
AT-1101E SERIES

DR: *Ricky* 2014/03/24

DWG NO.:
ASI-1101E

CHKD: *Ricky* 2014/03/24

APPD:

SCALE	SHEET	REV.	CUSTOMER
1:1	1/1	A	DRAWING

THESE DRAWINGS AND SPECIFICATIONS ARE THE PROPERTY OF ACCURATE INNOTECH INC AND SHALL NOT BE REPRODUCED, COPIED OR USED IN ANY MANNER WITHOUT THE PRIOR WRITTEN CONSENT OF ACCURATE INNOTECH INC.