

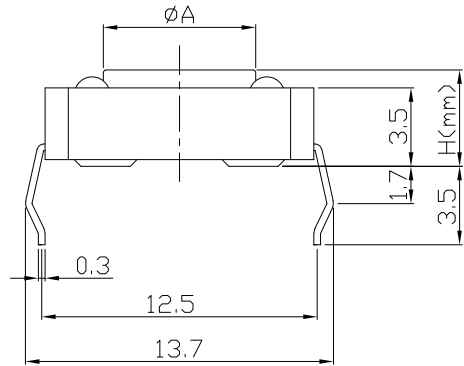

RoHS Compliant  
2002/95/EC

REV.	ECN. NO.	APPD.

### DIMENSIONS



### CIRCUIT DIAGRAM

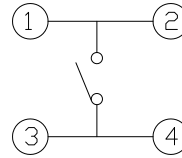

### PRODUCT IMAGE

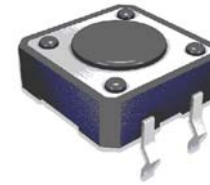

### MODEL CODE

AT-1103-

H	$\phi A$
4.3	6.8
5.0	6.8
5.5	6.8
6.0	6.8
6.5	6.7
7.0	6.7
7.5	6.7
8.0	6.7
8.5	6.6
9.0	6.6
9.5	6.6
10.0	6.0
10.5	6.0
11.0	6.0
11.5	6.0
12.0	6.0
13.0	6.0

P.C.B MOUNTING PATTERN DIMENSION  
The following soldering patterns are recommended for reflow soldering

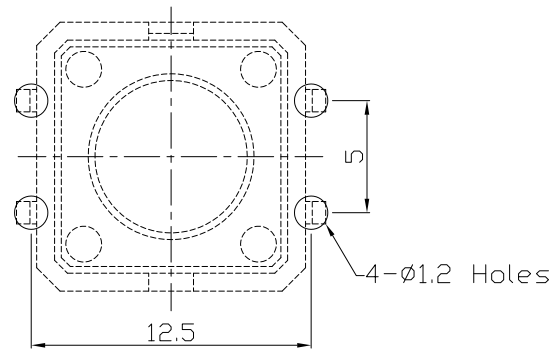
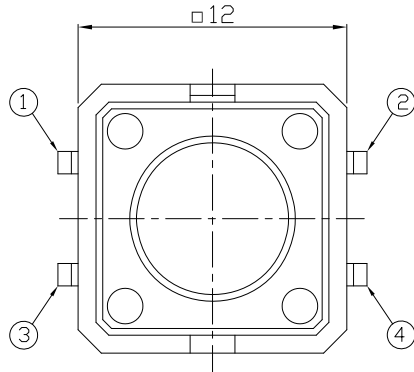

ELECTRO-MECHANICAL CHARACTERISTICS  
Refer to additional specifications

Rating	DC 12V 50mA	
Contact Resistance	100m $\Omega$ Max.	
Travel	0.3 $\pm$ 0.1mm	
Operating Force	130,160 $\pm$ 30gf	250 $\pm$ 50gf
Operating Life(cycles)	100,000	

.X $\pm$ 0.3	X. $\pm$ 2'
UNITS mm	MAT'L SEE NOTE
FINISH SEE NOTE	Q'TY

THESE DRAWINGS AND SPECIFICATIONS ARE THE PROPERTY OF ACCURATE INNOTECH INC AND SHALL NOT BE REPRODUCED, COPIED OR USED IN ANY MANNER WITHOUT THE PRIOR WRITTEN CONSENT OF ACCURATE INNOTECH INC.

雅安科技有限公司 ACCURATE INNOTECH INC.			
TITLE: TACT SWITCH		PART NO.: AT-1103 SERIES	
DR: <i>Ricky</i> 2014/03/27		DWG NO.: ASI-1103	
CHKD: <i>Ricky</i> 2014/03/27		SCALE	SHEET
APPD:		1:1	1/1
		REV. A	CUSTOMER DRAWING