



RoHS
Compliant
2002/95/EC

| REV. | ECN. | NO. | APPD. |
|------|------|-----|-------|
| | | | |
| | | | |
| | | | |

P.C.B MOUNTING PATTERN DIMENSION

DIMENSIONS

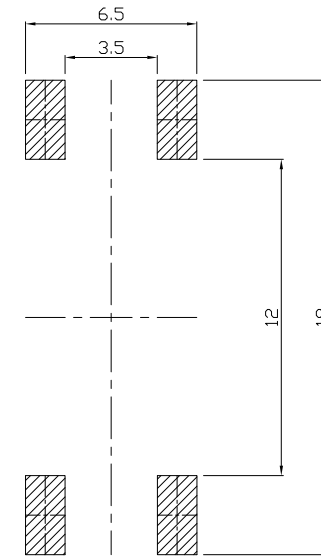
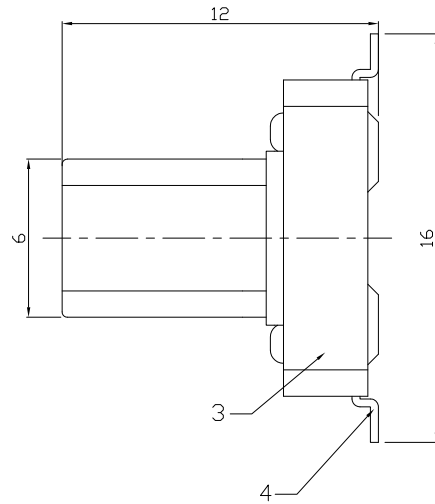
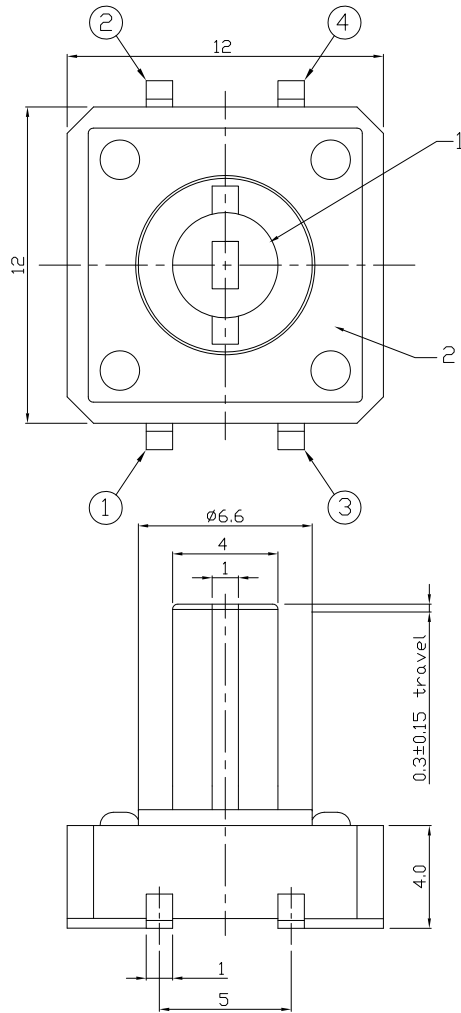

CIRCUIT DIAGRAM

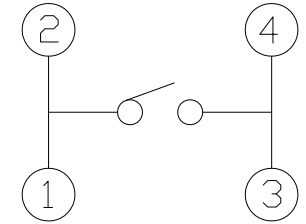

ELECTRO-MECHANICAL CHARACTERISTICS

Refer to additional specifications

| | | |
|------------------------|-------------|-----------|
| Rating | DC 12V 50mA | |
| Contact Resistance | 100mΩ Max. | |
| Travel | 0.3±0.15mm | |
| Operating Force | 160±50gf | 250±100gf |
| Operating Life(cycles) | 100,000 | |

| NO. | PART NAME | MATERIAL | QTY. | FINISHING |
|-----|--------------|-------------|------|------------|
| 5 | SPRING PLATE | PBS | 1 | Ag CLAD |
| 4 | TERMINAL | BRASS STRIP | 4 | Ag COATING |
| 3 | CASE | NYLON+F.G | 1 | BLACK |
| 2 | COVER | MILD STEEL | 1 | Ni COATING |
| 1 | KNOB | NYLON+F.G | 1 | NATURAL |

| | |
|-------------------|-----------------|
| WITHIN 1.5mm ±0.1 | UNITS mm |
| OVER 1.5mm ±0.2 | |
| | MAT'L SEE NOTE |
| | FINISH SEE NOTE |
| | Q'TY |

| | | | |
|------------------------------------|--|----------------------------|------------------|
| 雅安科技有限公司 ACCURATE INNOTECH INC. | | | |
| TITLE: TACT SWITCH | | PART NO.: AT-1103SA SERIES | |
| DR: Ricky 2017/09/20 | | DWG NO.: AZJ-1103SA | |
| CHKD: Ricky 2017/09/20 | | SCALE: 4:1 | SHEET: 1/1 |
| APPD: | | REV.: A | CUSTOMER DRAWING |

THESE DRAWINGS AND SPECIFICATIONS ARE THE PROPERTY OF ACCURATE INNOTECH INC AND SHALL NOT BE REPRODUCED, COPIED OR USED IN ANY MANNER WITHOUT THE PRIOR WRITTEN CONSENT OF ACCURATE INNOTECH INC.

