



RoHS
Compliant
2002/95/EC

REV.	ECN.	NO.	APPD.

P.C.B MOUNTING PATTERN DIMENSION

DIMENSIONS

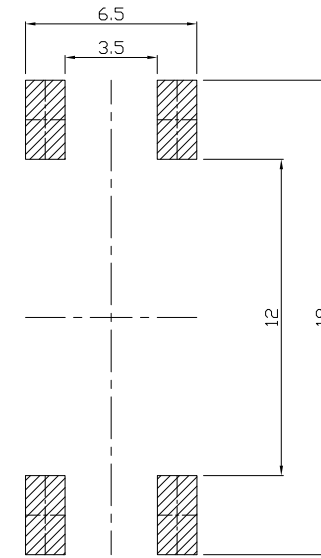
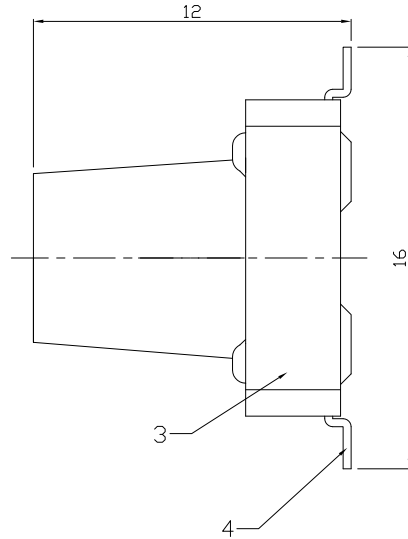
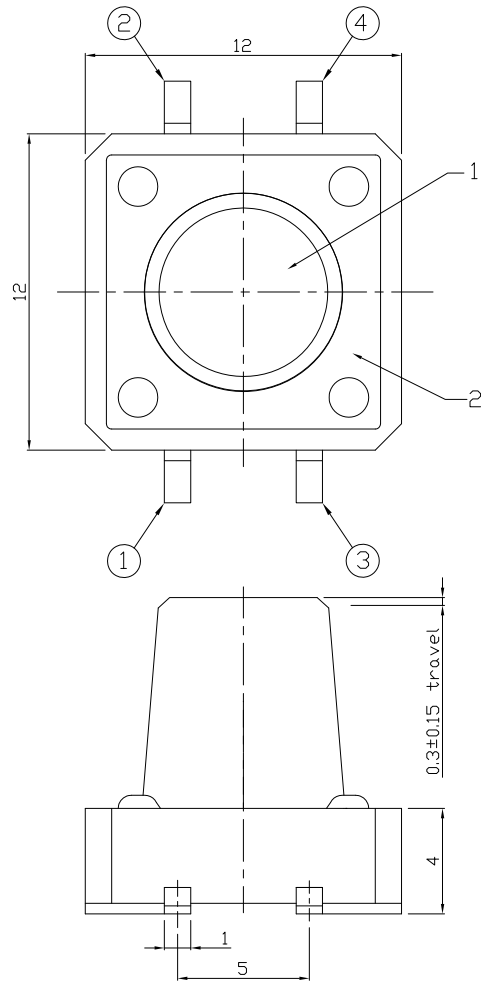

CIRCUIT DIAGRAM

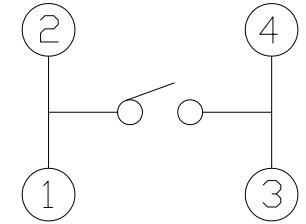

ELECTRO-MECHANICAL CHARACTERISTICS

Refer to additional specifications

Rating	DC 12V 50mA	
Contact Resistance	100mΩ Max.	
Travel	0.3±0.15mm	
Operating Force	160±50gf	250±100gf
Operating Life(cycles)	100,000	

5	SPRING PLATE	PBS	1	Ag CLAD
4	TERMINAL	BRASS STRIP	4	Ag COATING
3	CASE	NYLON+F.G	1	BLACK
2	COVER	MILD STEEL	1	Ni COATING
1	KNOB	NYLON+F.G	1	GREY
NO.	PART NAME	MATERIAL	QTY.	FINISHING

WITHIN 1.5mm ±0.1	UNITS mm
OVER 1.5mm ±0.2	
	MAT'L SEE NOTE
	FINISH SEE NOTE
	Q'TY
<small>THESE DRAWINGS AND SPECIFICATIONS ARE THE PROPERTY OF ACCURATE INNOTECH INC AND SHALL NOT BE REPRODUCED, COPIED OR USED IN ANY MANNER WITHOUT THE PRIOR WRITTEN CONSENT OF ACCURATE INNOTECH INC.</small>	

雅安科技有限公司 ACCURATE INNOTECH INC.			
TITLE: TACT SWITCH		PART NO.: AT-1103SD SERIES	
DR: <i>Ricky</i> 2017/09/20		DWG NO.: AZJ-1103SD	
CHKD: <i>Ricky</i> 2017/09/20		SCALE: 4:1	SHEET: 1/1
APPD:		REV: A	CUSTOMER DRAWING