

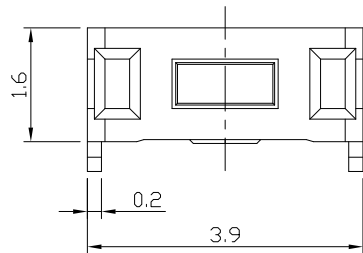

RoHS Compliant
2002/95/EC

REV.	ECN.	NO.	APPD.

DIMENSIONS

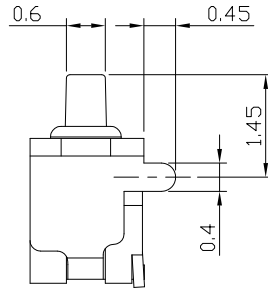
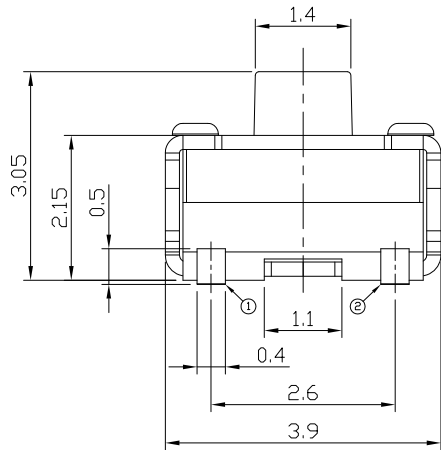

P.C.B MOUNTING PATTERN DIMENSION

The following soldering patterns are recommended for reflow soldering

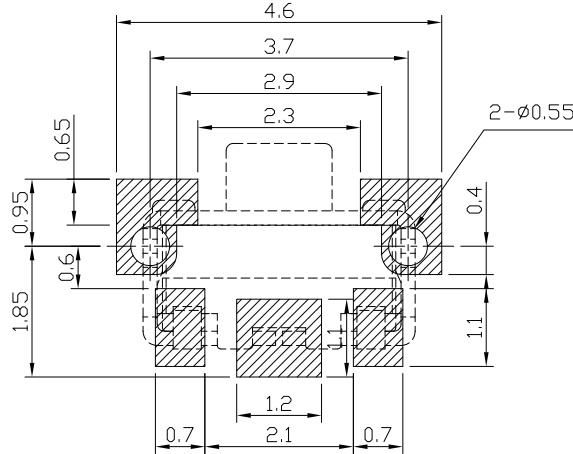

CIRCUIT DIAGRAM

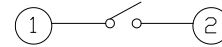

PRODUCT IMAGE



ELECTRO-MECHANICAL CHARACTERISTICS

Refer to additional specifications

Rating	DC 12V 50mA
Contact Resistance	100mΩ Max.
Travel	0.15 ± 0.1mm
Operating Force	160±50gf
Operating Life(cycles)	100,000

.X ±0.2	X. ±2'
UNITS	mm
MAT'L	SEE NOTE
FINISH	SEE NOTE
Q'TY	

THESE DRAWINGS AND SPECIFICATIONS ARE THE PROPERTY OF ACCURATE INNOTECH INC AND SHALL NOT BE REPRODUCED, COPIED OR USED IN ANY MANNER WITHOUT THE PRIOR WRITTEN CONSENT OF ACCURATE INNOTECH INC.

雅安科技有限公司 ACCURATE INNOTECH INC.			
TITLE: TACT SWITCH		PART NO.: AT-1179GS SERIES	
DR: <i>Ricky</i> 2018/05/11		DWG NO.: ASI-1179GS	
CHKD: <i>Ricky</i> 2018/05/11		SCALE	SHEET
APPD:		1:1	1/1
REV.	B	CUSTOMER	DRAWING