

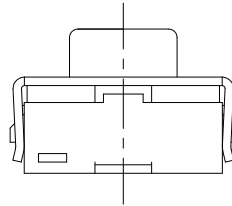

RoHS
Compliant
2002/95/EC

REV.	ECN.	NO.	APPD.

DIMENSIONS

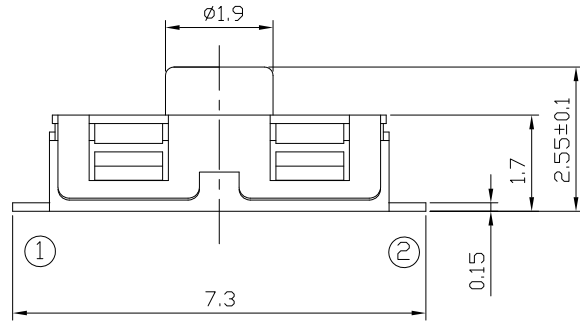

CIRCUIT DIAGRAM

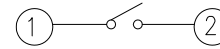

PRODUCT IMAGE

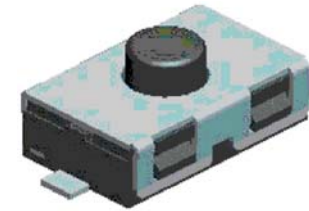

P.C.B MOUNTING PATTERN DIMENSION

The following soldering patterns are recommended for reflow soldering

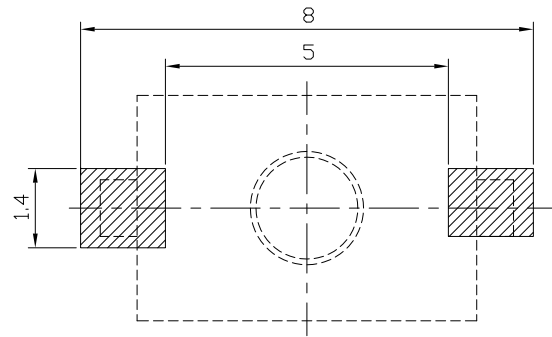
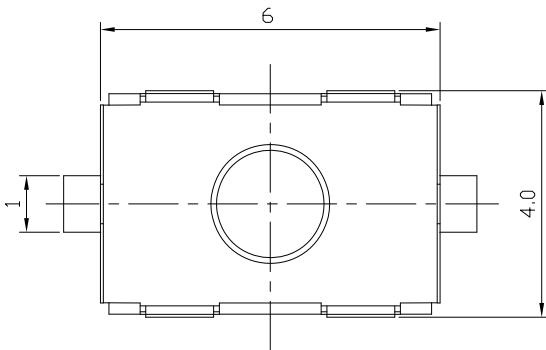

ELECTRO-MECHANICAL CHARACTERISTICS

Refer to additional specifications

Rating	DC 12V 50mA	
Contact Resistance	100mΩ Max.	
Travel	0.5 ± 0.2mm	
Operating Force	160±30gf	250±50gf
Operating Life(cycles)	100,000	50,000

.X ±0.2

X. ±2'

UNITS mm

MAT'L

SEE NOTE

FINISH

SEE NOTE

Q'TY

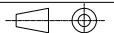

THESE DRAWINGS AND SPECIFICATIONS ARE THE PROPERTY OF ACCURATE INNOTECH INC AND SHALL NOT BE REPRODUCED, COPIED OR USED IN ANY MANNER WITHOUT THE PRIOR WRITTEN CONSENT OF ACCURATE INNOTECH INC.

雅安科技有限公司
ACCURATE INNOTECH INC.

TITLE:
TACT SWITCH

PART NO.:
AT-1181GJ SERIES

DR: *Ricky* 2017/04/06
CHKD: *Ricky* 2017/04/06

DWG NO.:
ASI-1181GJ

APPD:

SCALE	SHEET	REV.	CUSTOMER DRAWING
1:1	1/1	A	