

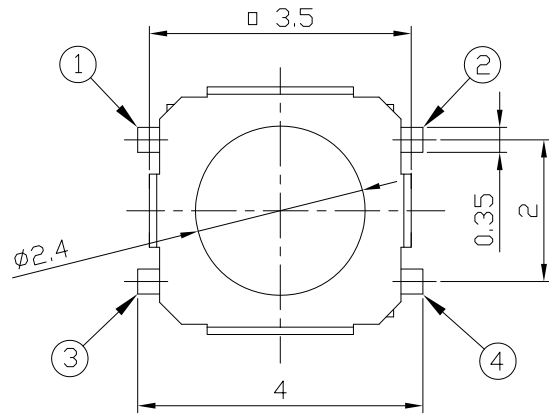

RoHS  
Compliant  
2002/95/EC

REV.	ECN.	NO.	APPD.

### DIMENSIONS



### CIRCUIT DIAGRAM

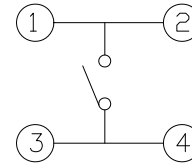

### PRODUCT IMAGE

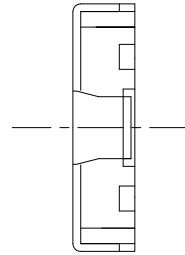
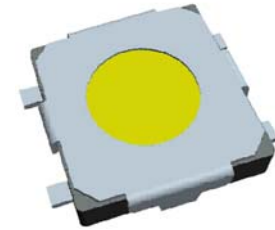

### P.C.B MOUNTING PATTERN DIMENSION

The following soldering patterns are recommended for reflow soldering

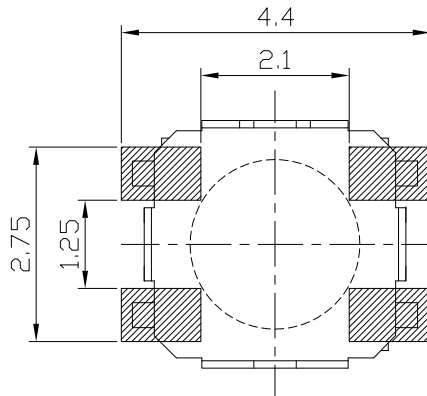
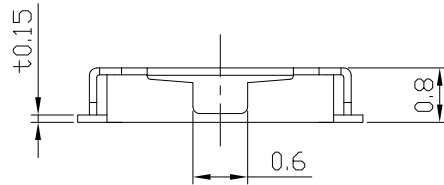

### ELECTRO-MECHANICAL CHARACTERISTICS

Refer to additional specifications

Rating	DC 12V 50mA	
Contact Resistance	100mΩ Max.	
Travel	0.15 ± 0.1mm	
Operating Force	160±30gf	250±50gf
Operating Life(cycles)	100,000	

.X ±0.2

X. ±2'

UNITS mm

MAT'L

SEE NOTE

FINISH

SEE NOTE

Q'TY

THESE DRAWINGS AND SPECIFICATIONS ARE THE PROPERTY OF ACCURATE INNOTECH INC AND SHALL NOT BE REPRODUCED, COPIED OR USED IN ANY MANNER WITHOUT THE PRIOR WRITTEN CONSENT OF ACCURATE INNOTECH INC.

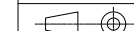

雅安科技有限公司  
ACCURATE INNOTECH INC.

TITLE:  
TACT SWITCH

PART NO.:  
AT-1184N SERIES

DR: *Ricky* 2014/03/28

DWG NO.:  
ASI-1184N

CHKD: *Ricky* 2014/03/28

APPD:

SCALE	SHEET	REV.	CUSTOMER
1:1	1/1	A	DRAWING