

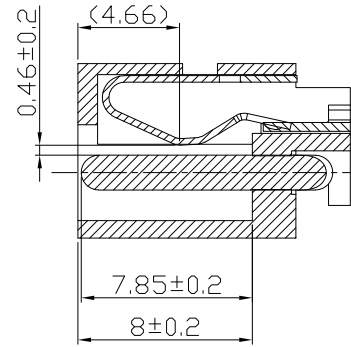

RoHS
Compliant
2002/95/EC

| REV. | ECN. NO. | APPD. |
|------|----------|-------|
| | | |
| | | |

DIMENSIONS

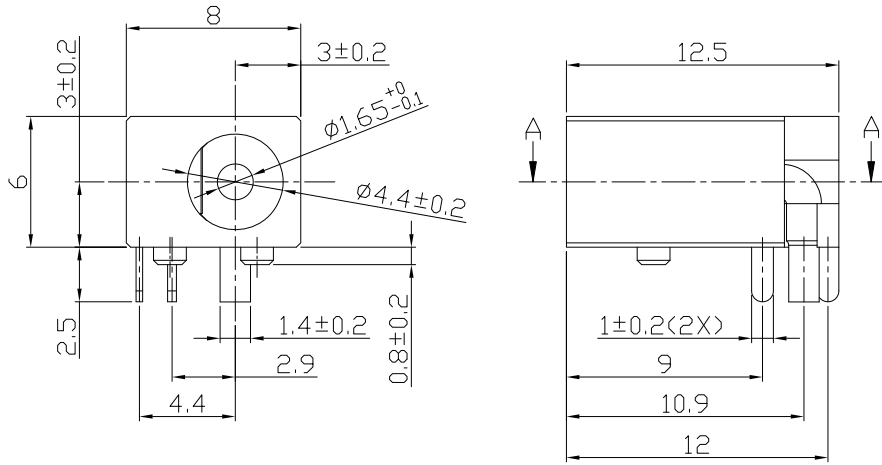

Section: A-A

MODEL CODE:

DCB0-0023A- A G PB BK S 0 4

- (1): Series type: DIP DC POWER JACK.
 (2): Series No.
 (3): Schematic option: A
 (4): Center pin diameter:
 G=0.165
 (5): Material of housing:
 PB=PBT
 (6): Housing color:
 BK=Black, 4D=Yellow(0417)
 (7): Terminal plating
 S=Silver(Ag)
 (8): Special option:
 0=No special option
 (9): Packing mode:
 4=Bag packing

SPECIFICATION:

- Rating : DC 20V 3A;
- Contact resistance: $\leq 30m\Omega$;
After test: $\leq 50m\Omega$
- Insulation resistance: $\geq 100M\Omega$ (DC500V);
After test: $\geq 50M\Omega$
- Withstand voltage: 500VAC ;
- Insertion and extraction force: 3-30N;
- life test: 5,000 cycles;
- Operation temperature range: $-20^{\circ}C \sim 70^{\circ}C$;
- Preservative temperature range: $-40^{\circ}C \sim 85^{\circ}C$;

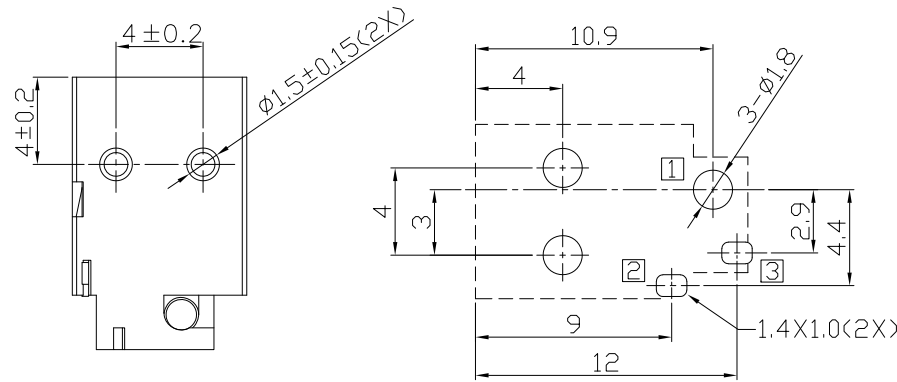

RECOMMENDED P.C.B. LAYOUT
 UNSPECIFIED TOLERANCE: ± 0.05
 (BOTTOM VIEW)

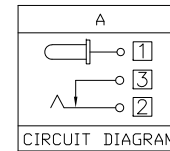
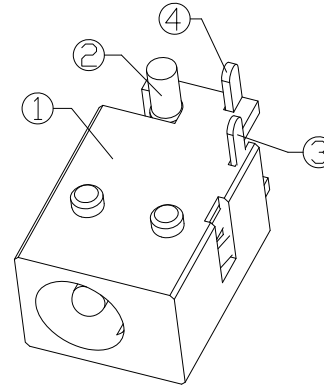

CIRCUIT DIAGRAM

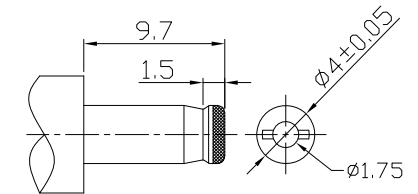

DC MATE PLUG

○: ITEM NO. □: TERMINAL NO.

| NO. | PARTS | MATERIAL | Q'TY | FINISHING | TOLERANCE | ANGLES | UNITS | 雅安科技有限公司 ACCURATE INNOTECH INC. | | | |
|-----|------------------|-----------------------|------|----------------|-----------|--------|----------|------------------------------------|--|----------------------|--|
| | | | | | ±0.3 | ±2' | mm | TITLE: DIP DC POWER JACK | | PART NO.: DCB0-0023A | |
| ④ | Shunt terminal ③ | Brass t=0.4 | 1 | Silver plating | | | MAT'L | DR: Ricky 2019/04/10 | | DWG NO.: AB0-0023A | |
| ③ | Tip spring ② | Phosphor bronze t=0.3 | 1 | Silver plating | | | SEE NOTE | CHKD: Ricky 2019/04/10 | | SCALE: 1:1 | |
| ② | Center pin ① | Brass | 1 | Silver plating | | | FINISH | APPD: | | SHEET: 1/1 | |
| ① | Housing | PBT | 1 | | | | Q'TY | | | REV. A | |
| | | | | | | | | | | CUSTOMER DRAWING | |

THESE DRAWINGS AND SPECIFICATIONS ARE THE PROPERTY OF ACCURATE INNOTECH INC AND SHALL NOT BE REPRODUCED, COPIED OR USED IN ANY MANNER WITHOUT THE PRIOR WRITTEN CONSENT OF ACCURATE INNOTECH INC.