

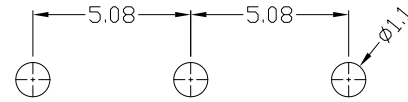

RoHS
Compliant
2002/95/EC

REV.	ECN.	NO.	APPD.

DIMENSIONS

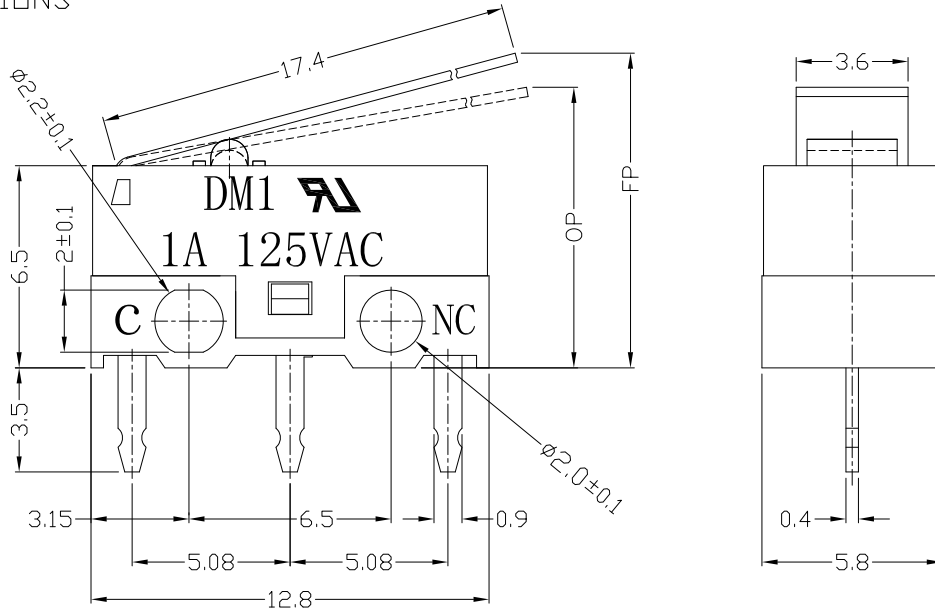

MODEL CODE

DM 1-03 X-XX-3
1 2 3 4 5 6

P.C.B LAYOUT

- 1.Series : DM
- 2.Current Rating : 1=1A 125VAC ; 30mA DC5V
- 3.Actuator : 00=non-lever 01-99=Lever
- 4.Termination : see chart (P/C/D/T/N)
- 5.Operating Force : see chart
- 6.Button colour : 3=white
- 7.Cover type : No-0=have two lines

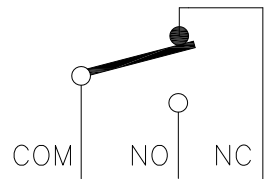

CIRCUIT DIAGRAM

1.Functional spec

1.1 Rated Voltage	125VAC/DC5V
1.2 Rated Current	1A/30mA
1.3 Contact Resistance	≤100mΩ(Initial value)
1.4 Operating Force	25±15gf 30±15gf
1.5 Bounce Time	
1.6 Free Position	11.0±1.0mm
1.7 Operating Position	9.2±1.0mm
1.8 Position Travel	
1.9 Return Force	

2.Reliable Rating

2.1 Mechanical Life	1,000,000 CYCLES
2.2 Electrical Life	10,000 CYCLES
2.3 Insulation Resistance	≥100MΩ DC500V
2.4 Withstand Voltage	AC500V 1 minute
2.5 Soldering Technic	Hand Soldering
2.6 Operating Temper	-25°C ~ +65°C
2.7 Ambient Humidity Used	<85%RH

Tolerance:±0.2	UNITS mm	雅安科技有限公司 ACCURATE INNOTECH INC.				
	MAT'L					
	SEE NOTE	TITLE:	PART NO:			
	FINISH	MICRO SWITCH DM SERIES	DM1-03P-XX-3			
	SEE NOTE	DR: <i>Ricky</i> 2017/2/17	DWG NO:			
	Q'TY	CHKD: <i>Ricky</i> 2017/2/17	ATD-03X-XX-3			
THESE DRAWINGS AND SPECIFICATIONS ARE THE PROPERTY OF ACCURATE INNOTECH INC AND SHALL NOT BE REPRODUCED, COPIED OR USED IN ANY MANNER WITHOUT THE PRIOR WRITTEN CONSENT OF ACCURATE INNOTECH INC.		APPD:	SCALE	SHEET	REV.	CUSTOMER DRAWING
			1:1	1/2	A	



RoHS Compliant
2002/95/EC

REV.	ECN. NO.	APPD.

Terminal Type

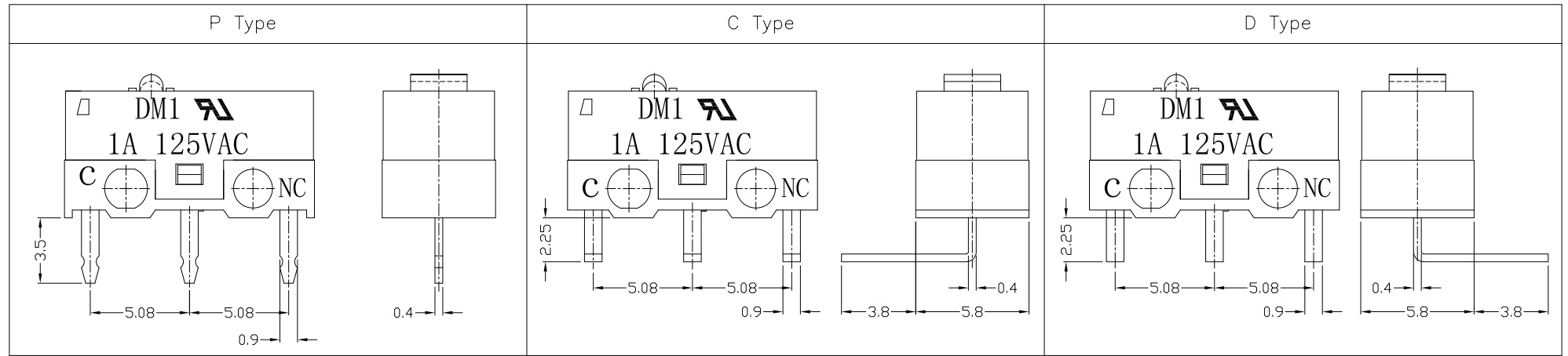

Structure chart

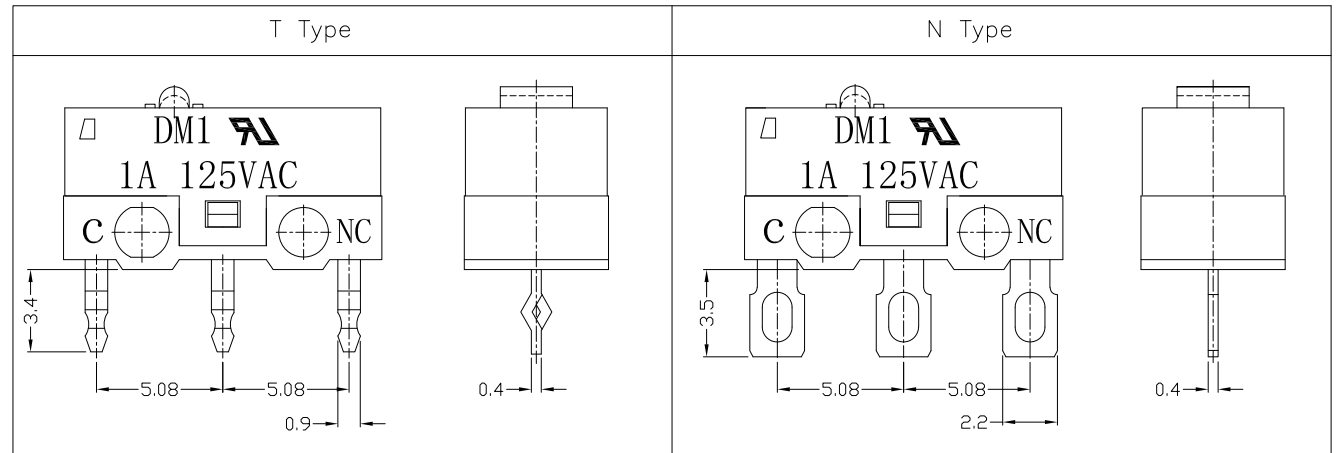
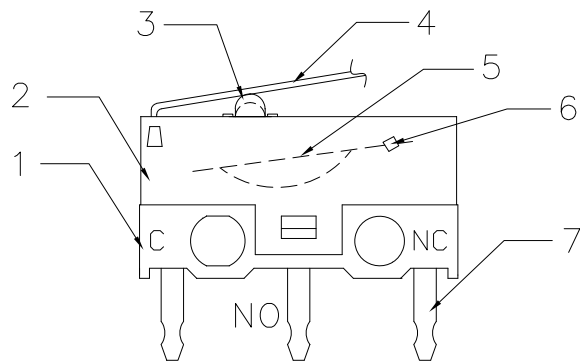

Material list

NO.	PARTS	MATERIAL	Q'TY	FINISHING	UNITS	mm	雅安科技有限公司 ACCURATE INNOTECH INC.			
8					Tolerance: ±0.2		TITLE: MICRO SWITCH DM SERIES		PART NO.: DM1-03X-XX-3	
7	Terminal	C2680	3				DR: Ricky 2017/2/17		DWG NO.: ATD-03X-XX-3	
6	Contact	Silver alloy	1				CHKD: Ricky 2017/2/17		SCALE: 1:1	
5	Spring Plate	C1720	1				APPD:		SHEET: 2/2	
4	Lever	SUS301	1						REV.: A	
3	Button	PBT	1	WHITE					CUSTOMER DRAWING	
2	Case	PBT	1	BLACK						
1	Base	PBT	1	WHITE						
					<small>THESE DRAWINGS AND SPECIFICATIONS ARE THE PROPERTY OF ACCURATE INNOTECH INC AND SHALL NOT BE REPRODUCED, COPIED OR USED IN ANY MANNER WITHOUT THE PRIOR WRITTEN CONSENT OF ACCURATE INNOTECH INC.</small>					



RoHS Compliant
2002/95/EC

REV.	ECN.	NO.	APPD.

DIMENSIONS

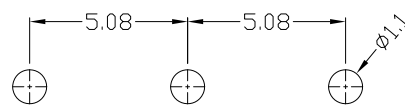
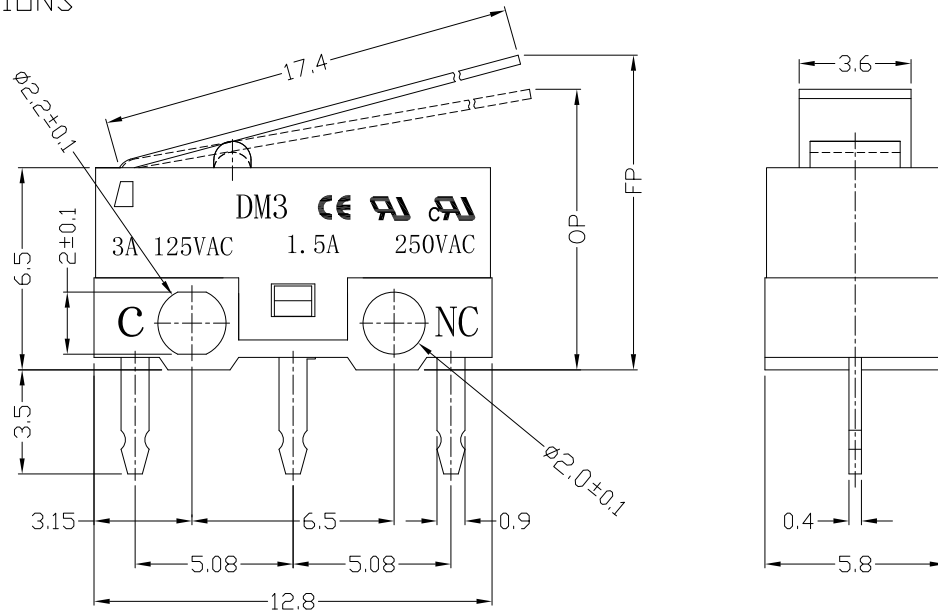

MODEL CODE

DM 3-03 X-XX-6-0
1 2 3 4 5 6 7

P.C.B LAYOUT

- 1.Series : DM
- 2.Current Rating : 3=3A 125VAC ; 1.5A 250VAC
- 3.Actuator : 00=non-lever 01-99=Lever
- 4.Termination : see chart (P/C/D/T/N)
- 5.Operating Force : see chart
- 6.Button colour : 6=grey
- 7.Cover type : 0=No two lines

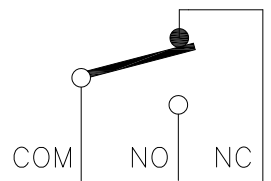

CIRCUIT DIAGRAM

1.Functional spec

1.1 Rated Voltage	125VAC/250VAC
1.2 Rated Current	3A/1.5A
1.3 Contact Resistance	≤100mΩ(Initial value)
1.4 Operating Force	25±15gf 30±15gf
1.5 Bounce Time	
1.6 Free Position	11.0±1.0mm
1.7 Operating Position	9.2±1.0mm
1.8 Position Travel	
1.9 Return Force	

2.Reliable Rating

2.1 Mechanical Life	1,000,000 CYCLES
2.2 Electrical Life	10,000 CYCLES
2.3 Insulation Resistance	≥100MΩ DC500V
2.4 Withstand Voltage	AC500V 1 minute
2.5 Soldering Technic	Hand Soldering
2.6 Operating Temper	-25°C ~ +65°C
2.7 Ambient Humidity Used	<85%RH

Tolerance:±0.2		UNITS	雅安科技有限公司 ACCURATE INNOTECH INC.			
		mm	TITLE:		PART NO.:	
		MAT'L	MICRO SWITCH DM SERIES		DM3-03P-XX-6-0	
		SEE NOTE	DR: <i>Ricky</i> 2017/2/21		DWG NO.:	
		FINISH	CHKD: <i>Ricky</i> 2017/2/21		ATD-03X-XX-6-0	
		SEE NOTE	APPD:		SCALE	SHEET
		Q'TY			1:1	1/2
THESE DRAWINGS AND SPECIFICATIONS ARE THE PROPERTY OF ACCURATE INNOTECH INC AND SHALL NOT BE REPRODUCED, COPIED OR USED IN ANY MANNER WITHOUT THE PRIOR WRITTEN CONSENT OF ACCURATE INNOTECH INC.					REV.	CUSTOMER
					A	DRAWING



RoHS Compliant
2002/95/EC

REV.	ECN. NO.	NO.	APPD.

Terminal Type

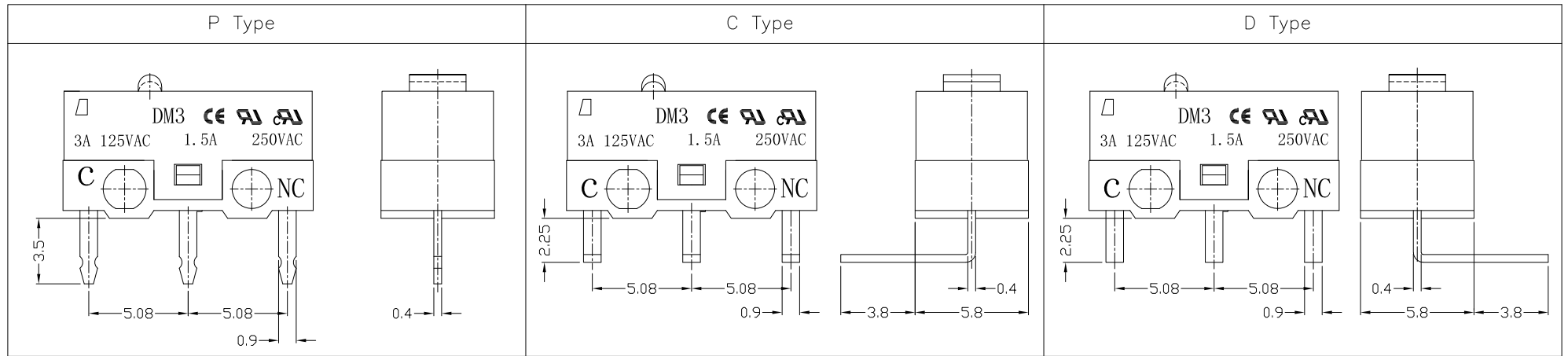

Structure chart

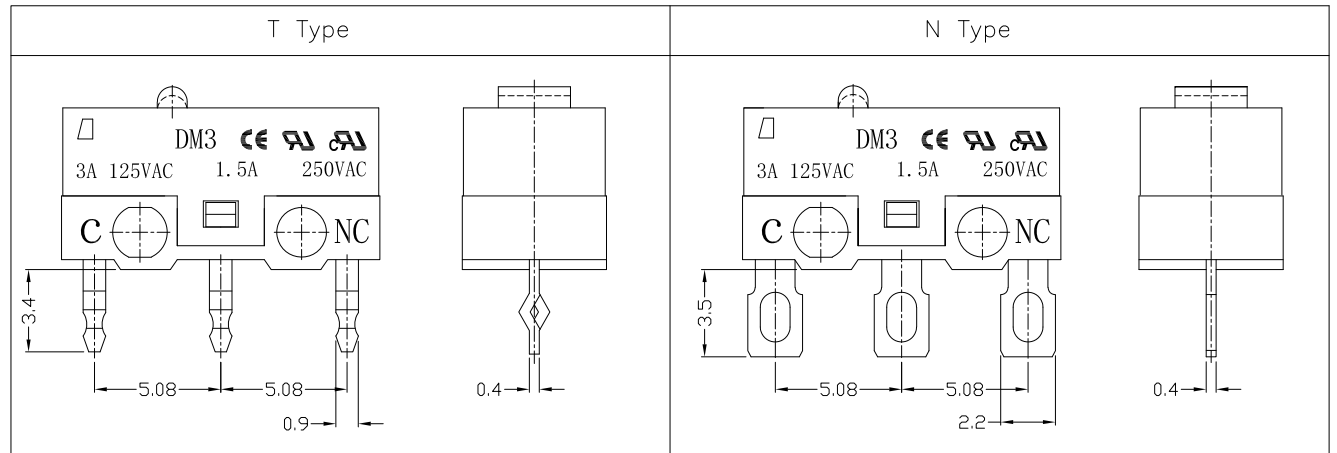
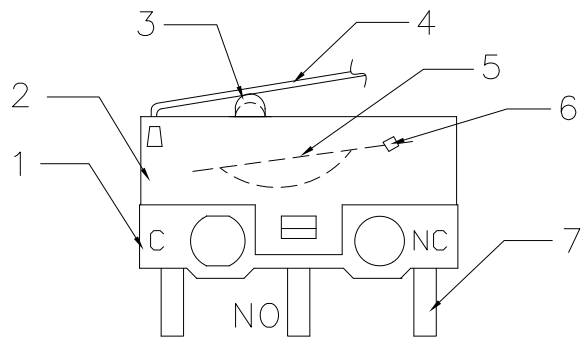

Material list

NO.	PARTS	MATERIAL	Q'TY	FINISHING
8				
7	Terminal	C2680	3	
6	Contact	Silver alloy	3	
5	Spring Plate	C1720	1	
4	Lever	SUS301	1	
3	Button	Nylon	1	GREY
2	Case	PBT	1	BLACK
1	Base	PBT	1	WHITE

Tolerance: ±0.2

UNITS mm

MAT'L

SEE NOTE

FINISH

SEE NOTE

Q'TY

THESE DRAWINGS AND SPECIFICATIONS ARE THE PROPERTY OF ACCURATE INNOTECH INC AND SHALL NOT BE REPRODUCED, COPIED OR USED IN ANY MANNER WITHOUT THE PRIOR WRITTEN CONSENT OF ACCURATE INNOTECH INC.

雅安科技有限公司 ACCURATE INNOTECH INC.			
TITLE: MICRO SWITCH DM SERIES		PART NO.: DM3-03X-XX-6-0	
DR: <i>Ricky</i> 2017/2/21		DWG NO.: ATD-03X-XX-6-0	
CHKD: <i>Ricky</i> 2017/2/21		SCALE	SHEET
APPD:		1:1	2/2
		REV.	CUSTOMER DRAWING
		A	