

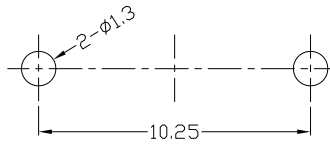

RoHS
Compliant
2002/95/EC

REV.	ECN.	NO.	APPD.

DIMENSIONS

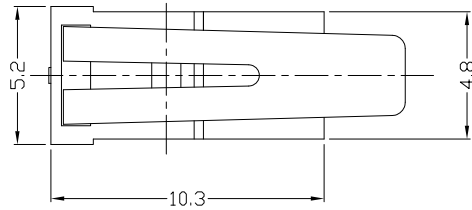

P.C.B LAYOUT
TOP VIEW

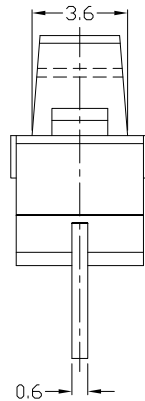
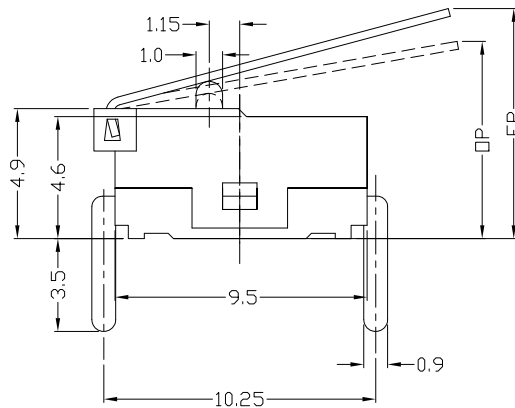

MODEL CODE

DS030-01X-30

1 2 3 4

- 1.Series : DS030
- 2.Actuator Button : 00=Non-lever 01-99=Lever
- 3.Termination : see chart (P/C/D)
- 4.Operating Force : see chart

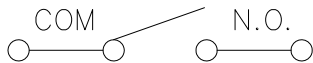

CIRCUIT DIAGRAM

1.Functional spec

1.1 Rated Voltage	DC48V/AC125V
1.2 Rated Current	0.1A
1.3 Contact Resistance	≤300mΩ(Initial value)
1.4 Operating Force	30±15gf
1.5 Bounce Time	
1.6 Free Position	8.0±0.8mm
1.7 Operating Position	6.7±0.8mm
1.8 Position Travel	
1.9 Return Force	

2.Reliable Rating

2.1 Mechanical Life	1,000,000 CYCLES
2.2 Electrical Life	1,000,000 CYCLES
2.3 Insulation Resistance	≥100MΩ DC250V
2.4 Withstand Voltage	AC250V 1 minute
2.5 Soldering Technic	Hand Soldering
2.6 Operating Temper	-15°C ~ +55°C
2.7 Ambient Humidity Used	<85%RH

Tolerance:±0.2	UNITS mm	雅安科技有限公司 ACCURATE INNOTECH INC.			
	MAT'L				
	SEE NOTE	TITLE:	PART NO:		
	FINISH	Miniature MICRO SWITCH DS030 SERIES	DS030-01P-30		
	SEE NOTE	DR: <i>Ricky</i> 2017/7/18	DWG NO: ATD-01X-30		
THESE DRAWINGS AND SPECIFICATIONS ARE THE PROPERTY OF ACCURATE INNOTECH INC AND SHALL NOT BE REPRODUCED, COPIED OR USED IN ANY MANNER WITHOUT THE PRIOR WRITTEN CONSENT OF ACCURATE INNOTECH INC.	Q'TY	CHKD: <i>Ricky</i> 2017/7/18	SCALE	SHEET	REV.
			1:1	1/2	A
		APPD:	CUSTOMER DRAWING		



RoHS
Compliant
2002/95/EC

REV.	ECN.	NO.	APPD.

Terminal Type

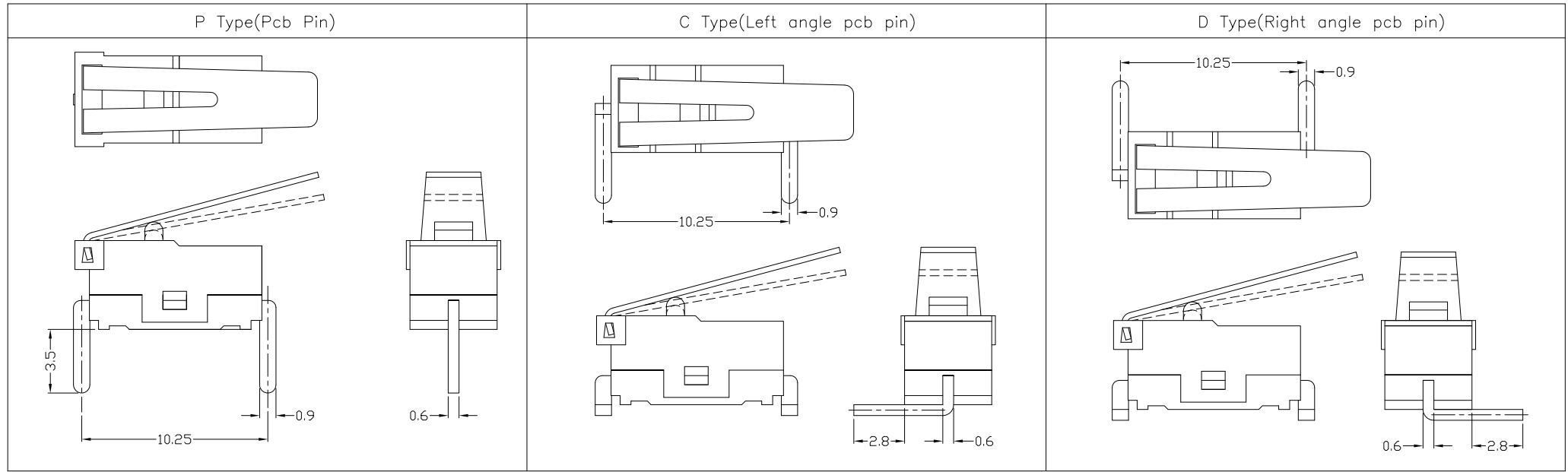

Structure chart

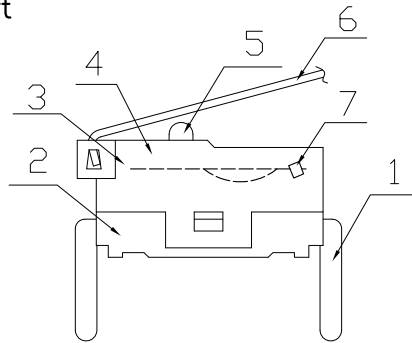

Material list

NO.	PARTS	MATERIAL	Q'TY	FINISHING	Tolerance:±0.2	UNITS	雅安科技有限公司 ACCURATE INNOTECH INC.			
8						mm	TITLE: 雅安科技有限公司 PART NO.: DS030-01X-30			
7	Contact	Silver alloy	1							
6	Lever	SUS301	1				CHKD: Ricky 2017/7/18 SCALE SHEET REV. CUSTOMER 1:1 2/2 A DRAWING			
5	Button	Nylon	1							
4	Spring Plate	C1720	1				SEE NOTE			
3	Case	Nylon	1							
2	Base	Nylon	1				FINISH			
1	Terminal	C2680	2							
					<small>THESE DRAWINGS AND SPECIFICATIONS ARE THE PROPERTY OF ACCURATE INNOTECH INC AND SHALL NOT BE REPRODUCED, COPIED OR USED IN ANY MANNER WITHOUT THE PRIOR WRITTEN CONSENT OF ACCURATE INNOTECH INC.</small>					