

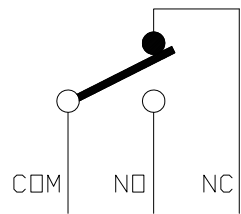

RoHS
Compliant
2002/95/EC

REV.	ECN.	NO.	APPD.

DIMENSIONS

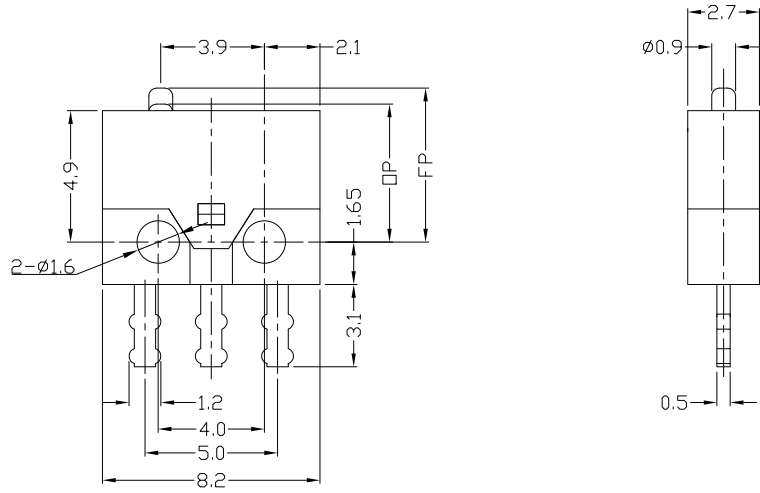

CIRCUIT DIAGRAM

MODEL CODE

DS037-00X-XX
1 2 3 4

- 1.Series : DS037
- 2.Actuator Button : 00=Non-lever 01-99=Lever
- 3.Termination : see chart(P/C/D/C1/D1)
- 4.Operating Force : see chart

1.Functional spec

1.1 Rated Voltage	DC 6V
1.2 Rated Current	0.3A
1.3 Contact Resistance	≤50mΩ(Initial value)
1.4 Operating Force	90±30gf
1.5 Bounce Time	
1.6 Free Position	5.2±0.2mm
1.7 Operating Position	5.0±0.2mm
1.8 Position Travel	
1.9 Return Force	

2.Reliable Rating

2.1 Mechanical Life	100,000 CYCLES
2.2 Electrical Life	50,000 CYCLES
2.3 Insulation Resistance	≥100MΩ DC250V
2.4 Withstand Voltage	AC250V 1 minute
2.5 Soldering Technic	Hand/Wave soldering
2.6 Operating Temper	-25°C ~ +85°C
2.7 Ambient Humidity Used	<85%RH

Tolerance:±0.2	UNITS mm	雅安科技有限公司 ACCURATE INNOTECH INC.			
	MAT'L				
	SEE NOTE	Miniature MICRO SWITCH DS037 SERIES	DS037-00P-90		
	FINISH	DR: Ricky 2017/7/19	DWG NO.:	ATD-00X-90	
	SEE NOTE	CHKD: Ricky 2017/7/19	SCALE	SHEET	REV.
THESE DRAWINGS AND SPECIFICATIONS ARE THE PROPERTY OF ACCURATE INNOTECH INC AND SHALL NOT BE REPRODUCED, COPIED OR USED IN ANY MANNER WITHOUT THE PRIOR WRITTEN CONSENT OF ACCURATE INNOTECH INC.	Q'TY	APPD:	1:1	1/2	A
					CUSTOMER DRAWING



RoHS
Compliant
2002/95/EC

REV.	ECN.	NO.	APPD.

Terminal Type

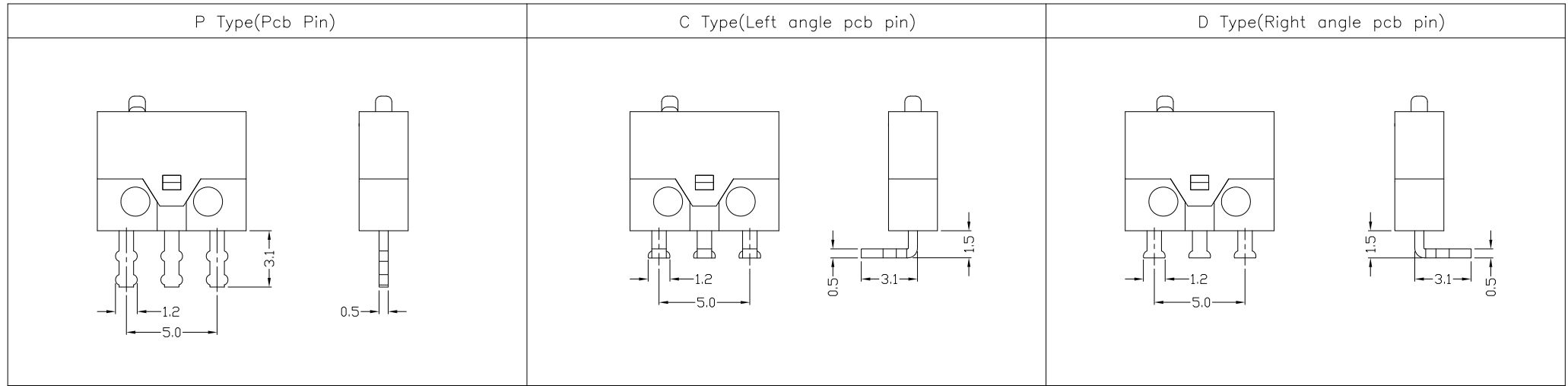

Structure chart

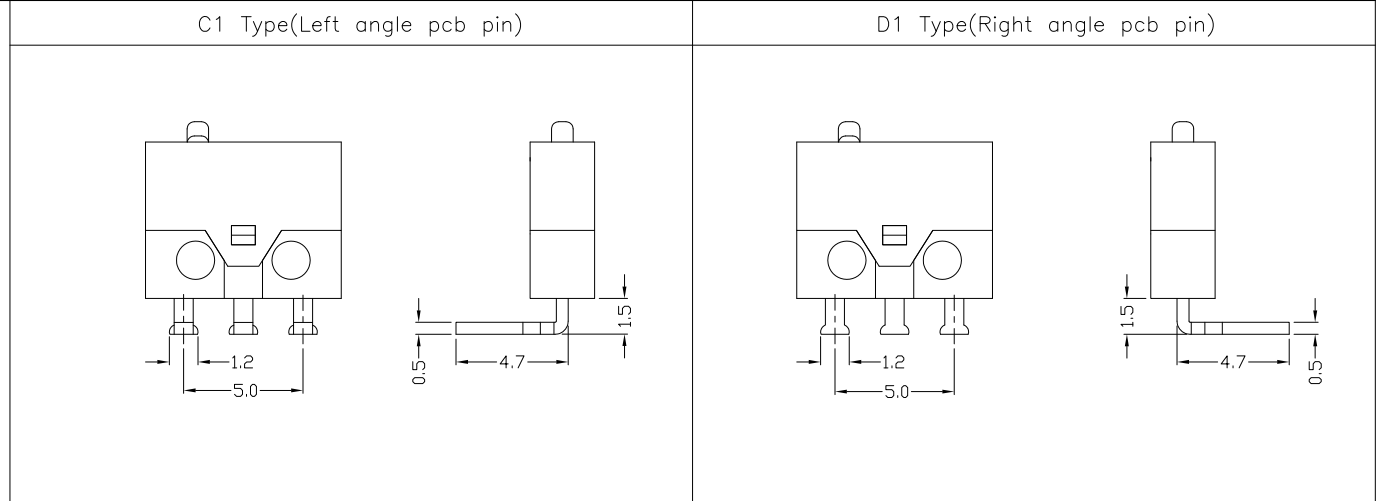
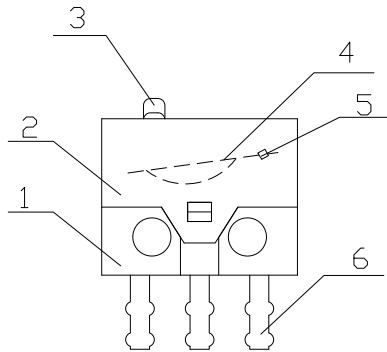

Material list

8					
7					
6	Terminal	C2680	2		
5	Contact	Silver alloy	1		
4	Spring Plate	C1720	1		
3	Button	Nylon	1		
2	Case	Nylon	1		
1	Base	Nylon	1		
NO.	PARTS	MATERIAL	Q'TY	FINISHING	

Tolerance:±0.2

UNITS mm

MAT'L
SEE NOTE

FINISH
SEE NOTE

Q'TY

THESE DRAWINGS AND SPECIFICATIONS ARE THE PROPERTY OF ACCURATE INNOTECH INC AND SHALL NOT BE REPRODUCED, COPIED OR USED IN ANY MANNER WITHOUT THE PRIOR WRITTEN CONSENT OF ACCURATE INNOTECH INC.

雅安科技有限公司 ACCURATE INNOTECH INC.			
TITLE: Miniature MICRO SWITCH DS037 SERIES		PART NO.: DS037-00X-90	
DR: <i>Ricky</i> 2017/7/19		DWG NO.: ATD-00X-90	
CHKD: <i>Ricky</i> 2017/7/19		SCALE 1:1	SHEET 2/2
APPD:		REV. A	CUSTOMER DRAWING