

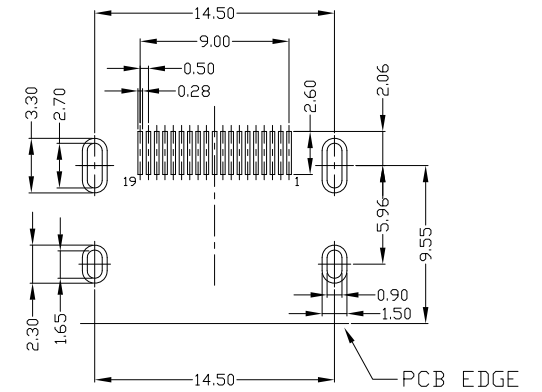

RoHS  
Compliant  
2002/95/EC

Halogen Free

REV.	ECN.	NO.	APPD.

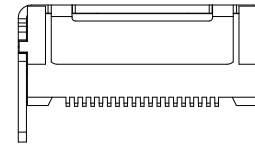
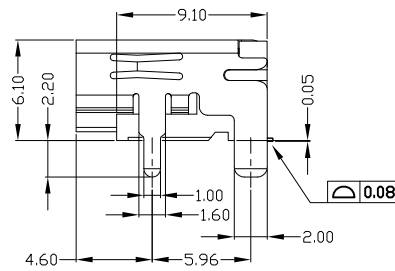
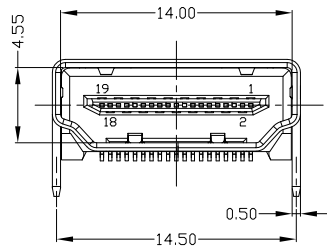
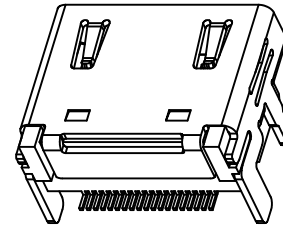
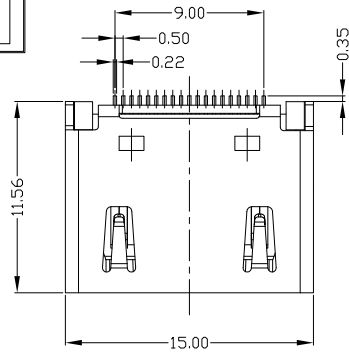

RECOMMENDED PCB LAYOUT (T=1.60mm)

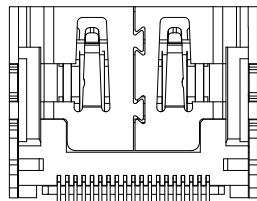

NOTES:

- ELECTRICAL:
  - VOLTAGE CURRENT RATING: 0.5AMP,30V AC;
  - INSULATION RESISTANCE: 1000MΩ MIN;
  - CONTACT RESISTANCE: 30mΩ MAX;
  - WITHSTANDING VOLTAGE: 500V AC;
  - OPERATING TEMPERATURE:-20°C TO +85°C.
- Mechanical:
  - Mating Force: 35N MAX
  - Unmating Force: 10N MIN.
- DIMENSIONS MARKED "▼" TO BE CHECKED BY Q.C & IPQC.

4.PART NO.

HMAF-191N-4BHS49-S-H

N: Ni  
G: Au  
1: Au 1U"  
5: Au 15U"

Bill of materials:

NO	PARTS	MATERIAL	QTY	FINISHING
3	HOUSING	LCP+30%GF	1	UL94V-0
2	SHELL	SPCC	1	PLATED NICKEL
1	TERMINAL	COPPER ALLOY	19	PLATED GOLD/TIN

UNITS mm			
X. ±0.35	X.' ±2'	MAT'L	SEE NOTE
.X ±0.3	.X' ±1'	FINISH	SEE NOTE
.XX ±0.25	.XX'	Q'TY	SEE NOTE
.XXX ±0.15	.XXX'	THESE DRAWINGS AND SPECIFICATIONS ARE THE PROPERTY OF ACCURATE INNOTECH INC AND SHALL NOT BE REPRODUCED, COPIED OR USED IN ANY MANNER WITHOUT THE PRIOR WRITTEN CONSENT OF ACCURATE INNOTECH INC.	

雅安科技有限公司  
ACCURATE INNOTECH INC.

TITLE:		PART NO.:	
HDMI AF 19PIN SMT 铁壳镀镍DIP脚无凸点 L=9.10 前脚1.0宽 无面		HMAF-191N-4BHS49-S-H	
DR:	gan 2017/07/2	DWG NO.:	AII-HS49-S-H
CHKD:	gan 2017/07/2	SCALE	SHEET
APPD:		1:1	1/1
		REV.	B
		CUSTOMER DRAWING	