

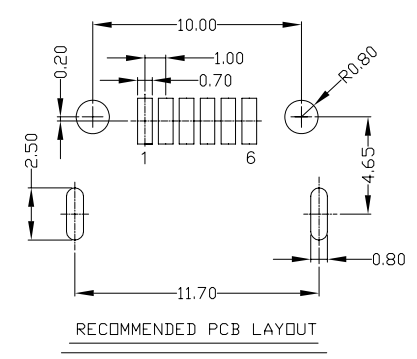

RoHS
Compliant
2002/95/EC

REV.	ECN.	NO.	APPD.

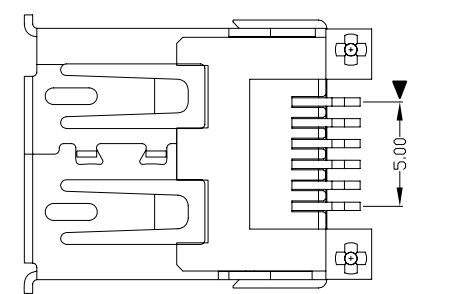
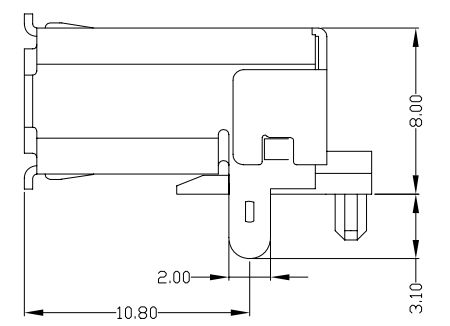
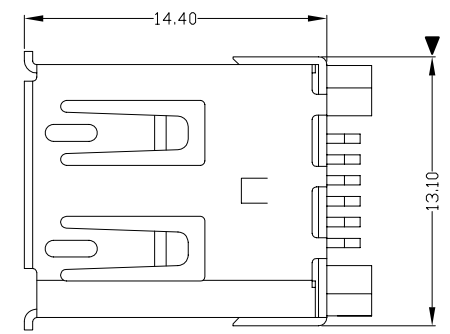
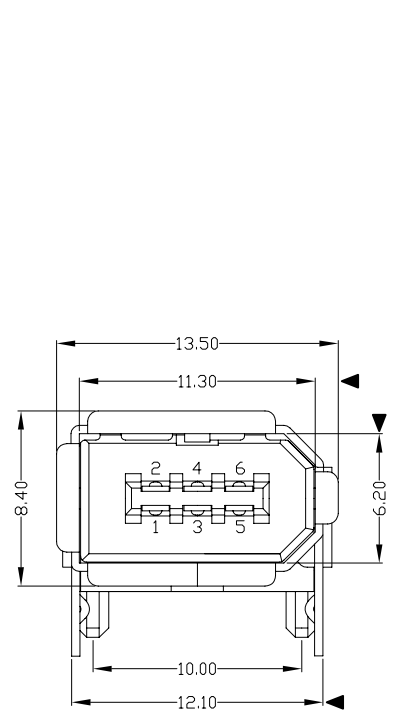

- NOTES:
- ELECTRICAL:
 - VOLTAGE CURRENT RATING: 1AMP,30V AC;
 - INSULATION RESISTANCE: 100MΩ MIN;
 - CONTACT RESISTANCE: 50mΩ MAX;
 - WITHSTANDING VOLTAGE: 300V AC;
 - OPERATING TEMPERATURE:-55°C TO +85°C.
 - Mechanical:
 - Mating Force: 30N MAX
 - Unmating Force: 7N MIN.
 - DIMENSIONS MARKED "▼" TO BE CHECKED BY Q.C & IPQC.
 - PART NO.

IENF-06*N-4*V80

W:WHITE
B:BLACK

1:Au 1U*
6:Au 30U*

1:PB
2:PA6T
3:PA9T
4:LCP

NO	PARTS	MATERIAL	QTY	FINISHING	X. ±0.35	X.* ±2*	UNITS	mm	雅安科技有限公司 ACCURATE INNOTECH INC.					
3	HOUSING	LCP	1	UL94V-0	.X ±0.3	.X* ±1*	MAT'L	SEE NOTE	TITLE: IEEE 1394 6P/F SMT		PART NO.: IENF-06*N-4*V80			
2	SHELL	COPPER ALLOY	1	PLATED NICKEL	.XX ±0.25	.XX*	FINISH	SEE NOTE	DR: gan 2013/01/18		DWG NO.: AII-V80			
1	TERMINAL	COPPER ALLOY	6	PLATED GOLD/TIN	.XXX ±0.15	.XXX*	Q'TY	SEE NOTE	CHKD: gan 2013/01/18		SCALE	SHEET	REV.	CUSTOMER DRAWING
<small>THESE DRAWINGS AND SPECIFICATIONS ARE THE PROPERTY OF ACCURATE INNOTECH INC AND SHALL NOT BE REPRODUCED, COPIED OR USED IN ANY MANNER WITHOUT THE PRIOR WRITTEN CONSENT OF ACCURATE INNOTECH INC.</small>							APPD:		1:1	1/1	B			