

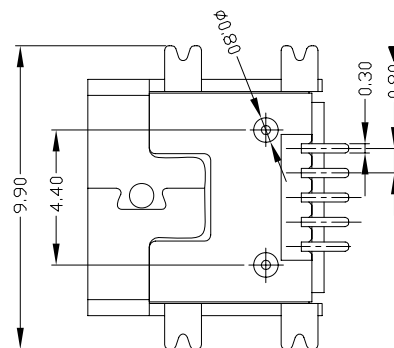

RoHS
Compliant
2002/95/EC

REV.	ECN. NO.	APPD.

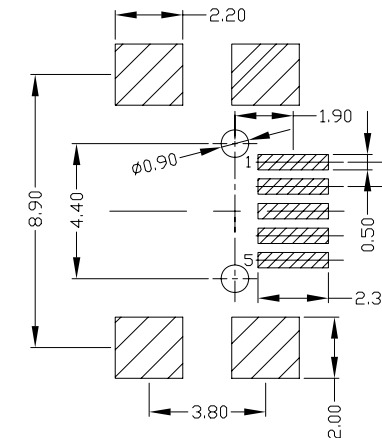
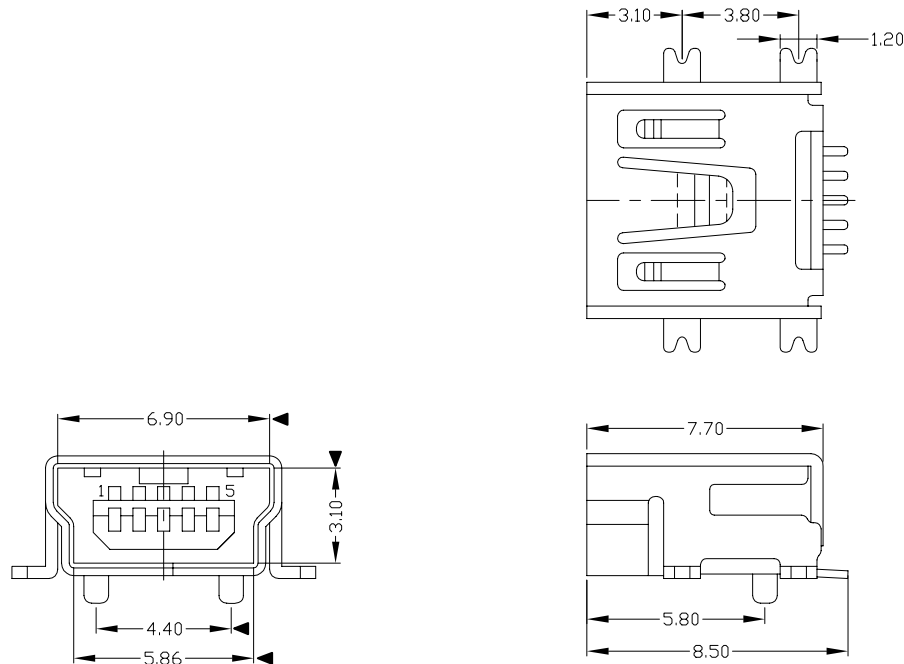

NOTES:

1. ELECTRICAL:

- VOLTAGE CURRENT RATING: 1.0AMP,30V AC;
- INSULATION RESISTANCE: 100M Ω MIN;
- CONTACT RESISTANCE: 50m Ω MAX;
- WITHSTANDING VOLTAGE: 300V AC;
- OPERATING TEMPERATURE:-55°C TO +85°C.

2. Mechanical:

- Mating Force: 30N MAX
- Unmating Force: 7N MIN.

3. DIMENSIONS MARKED "▼" TO BE CHECKED BY Q.C & IPQC.

4.PART NO.

MUBF-05*N-4BH86

1:1U*
6:Au 30U*

W:WHITE
B:BLACK

1:PBT
2:PA6T
3:PA9T
4:LCP

Bill of materials:

NO	PARTS	MATERIAL	QTY	FINISHING	X. ± 0.35	X.* $\pm 2^*$	UNITS	mm
3	HOUSING	LCP	1	UL94V-0	.X ± 0.3	.X.* $\pm 1^*$	MAT'L	SEE NOTE
2	SHELL	COPPER ALLOY	1	PLATED NICKEL	.XXX ± 0.15	.XXX*	FINISH	SEE NOTE
1	TERMINAL	COPPER ALLOY	5	PLATED GOLD/TIN	THESE DRAWINGS AND SPECIFICATIONS ARE THE PROPERTY OF ACCURATE INNOTECH INC AND SHALL NOT BE REPRODUCED, COPIED OR USED IN ANY MANNER WITHOUT THE PRIOR WRITTEN CONSENT OF ACCURATE INNOTECH INC.			
Q'TY	Q'TY							
APPD:	APPD:							

雅安科技有限公司
ACCURATE INNOTECH INC.

TITLE: MINI USB 5P/F SMT (短体) PART NO.: MUBF-05*N-4BH86

DR: gan 2012/7/02 DWG NO.: AII-H86

CHKD: gan 2012/7/02

SCALE: 1:1 SHEET: 1/1 REV: B CUSTOMER DRAWING