

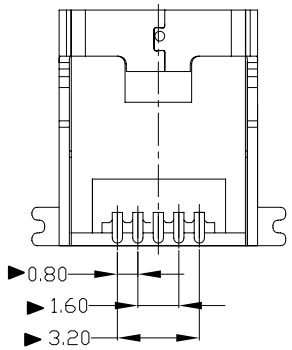

RoHS  
Compliant  
2002/95/EC

REV.	ECN.	NO.	APPD.

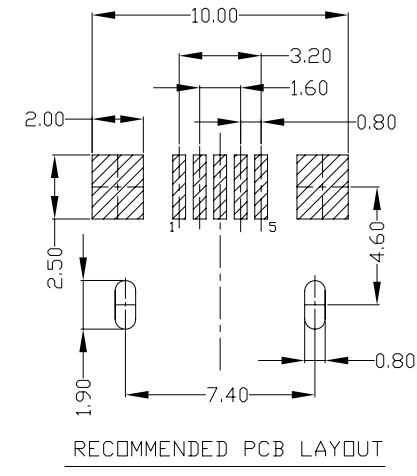
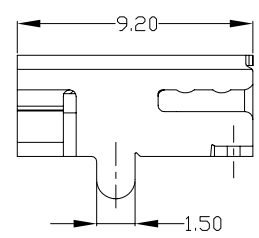
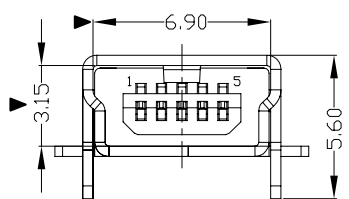
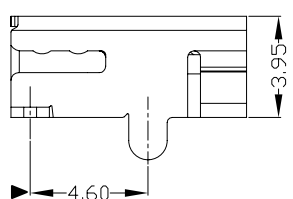
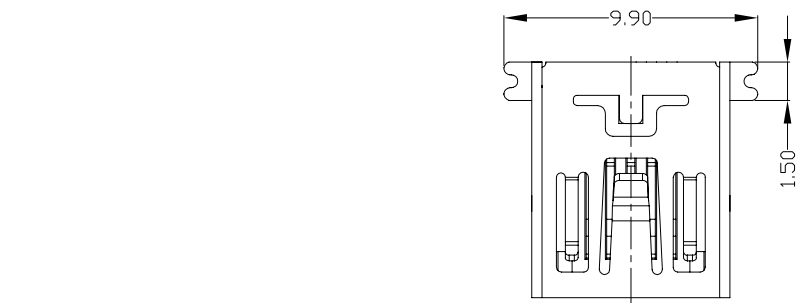

NOTES:

- ELECTRICAL:
  - VOLTAGE CURRENT RATING: 1.0AMP,30V AC;
  - INSULATION RESISTANCE: 100MΩ MIN;
  - CONTACT RESISTANCE: 50mΩ MAX;
  - WITHSTANDING VOLTAGE: 300V AC;
  - OPERATING TEMPERATURE:-55°C TO +85°C.
- Mechanical:
  - Mating Force: 30N MAX
  - Unmating Force: 7N MIN.
- DIMENSIONS MARKED "▼" TO BE CHECKED BY Q.C & IPQC.

4.PART NO.

MUBF-05\*N-4BH89  
 1:Au 1U\*  
 6:Au 30U\*  
 W:WHITE  
 B:BLACK  
 1:PBT  
 2:PA6T  
 3:PA9T  
 4:LCP

Bill of materials:

NO	PARTS	MATERIAL	QTY	FINISHING
3	HOUSING	LCP	1	UL94V-0
2	SHELL	COPPER ALLOY	1	PLATED NICKEL
1	TERMINAL	COPPER ALLOY	5	PLATED GOLD/TIN

雅安科技有限公司 ACCURATE INNOTECH INC.	
TITLE: MINT USB B TYPE 5PIN/F SMT 前插后贴	PART NO.: MUBF-05*N-4BH89
DR: gan 2012/7/02	DWG NO.: AII-H89
CHKD: gan 2012/7/02	SCALE SHEET REV. CUSTOMER 1:1 1/1 B DRAWING
APPD:	

THESE DRAWINGS AND SPECIFICATIONS ARE THE PROPERTY OF ACCURATE INNOTECH INC AND SHALL NOT BE REPRODUCED, COPIED OR USED IN ANY MANNER WITHOUT THE PRIOR WRITTEN CONSENT OF ACCURATE INNOTECH INC.

