

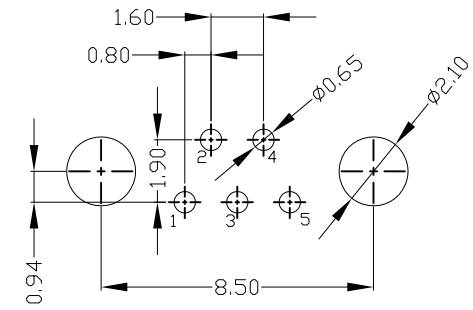

RoHS
Compliant
2002/95/EC

REV	LTR	DESCRIPTION	DATE	REVISER	APPD

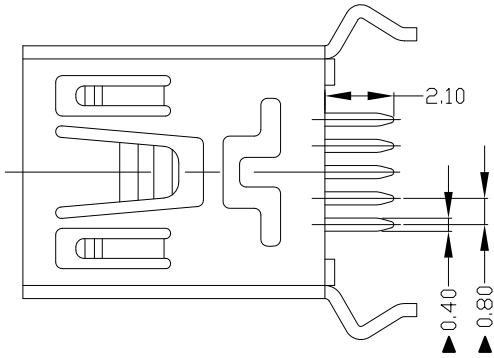

RECOMMENDED PCB LAYOUT

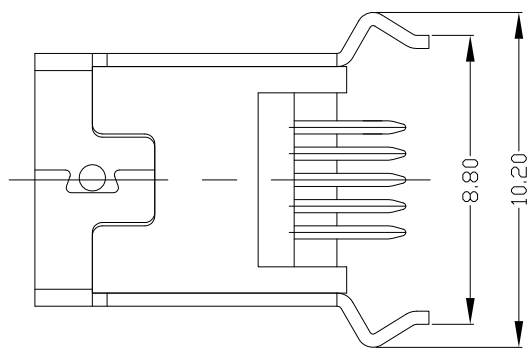
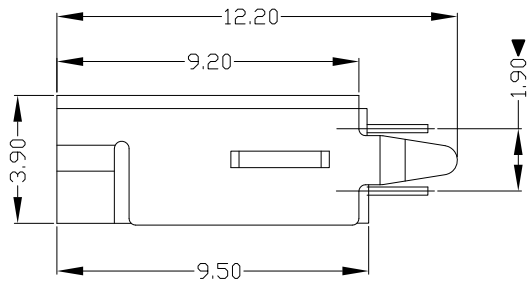
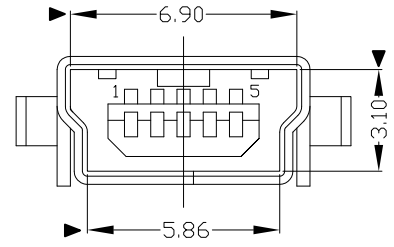

NOTES:

- ELECTRICAL:
 - VOLTAGE CURRENT RATING: 1.0AMP,30V AC;
 - INSULATION RESISTANCE: 100MΩ MIN;
 - CONTACT RESISTANCE: 50mΩ MAX;
 - WITHSTANDING VOLTAGE: 300V AC;
 - OPERATING TEMPERATURE:-55°C TO +85°C.
- Mechanical:
 - Mating Force: 30N MAX
 - Unmating Force: 7N MIN.
- DIMENSIONS MARKED "▼" TO BE CHECKED BY Q.C & IPQC.
- PART NO.

MUBF-05*N-4BP80

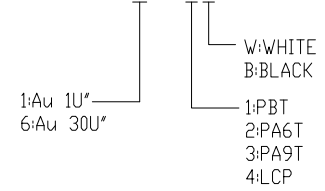

NO	PARTS	MATERIAL	QTY	FINISHING								
3	HOUSING	LCP	1	UL94V-0	X. ±0.35	X.' ±2'	UNITS	mm	雅安科技有限公司 ACCURATE INNOTECH INC. TITLE: MINI USB 5P/F 180° DIP B型 (弯脚) PART NO.: MUBF-05*N-4BP80 DR: gan 2012/7/02 DWG NO.: AII-P80 CHKD: gan 2012/7/02 APPD:			
2	SHELL	COPPER ALLOY	1	PLATED NICKEL	.X ±0.3	.X' ±1'	MAT'L	SEE NOTE				
1	TERMINAL	COPPER ALLOY	5	PLATED GOLD/TIN	.XX ±0.25	.XX'	FINISH	SEE NOTE				
					.XXX ±0.15	.XXX'	Q'TY					
					THESE DRAWINGS AND SPECIFICATIONS ARE THE PROPERTY OF ACCURATE INNOTECH INC AND SHALL NOT BE REPRODUCED, COPIED OR USED IN ANY MANNER WITHOUT THE PRIOR WRITTEN CONSENT OF ACCURATE INNOTECH INC.			SCALE				SHEET
									1:1	1/1	B	