

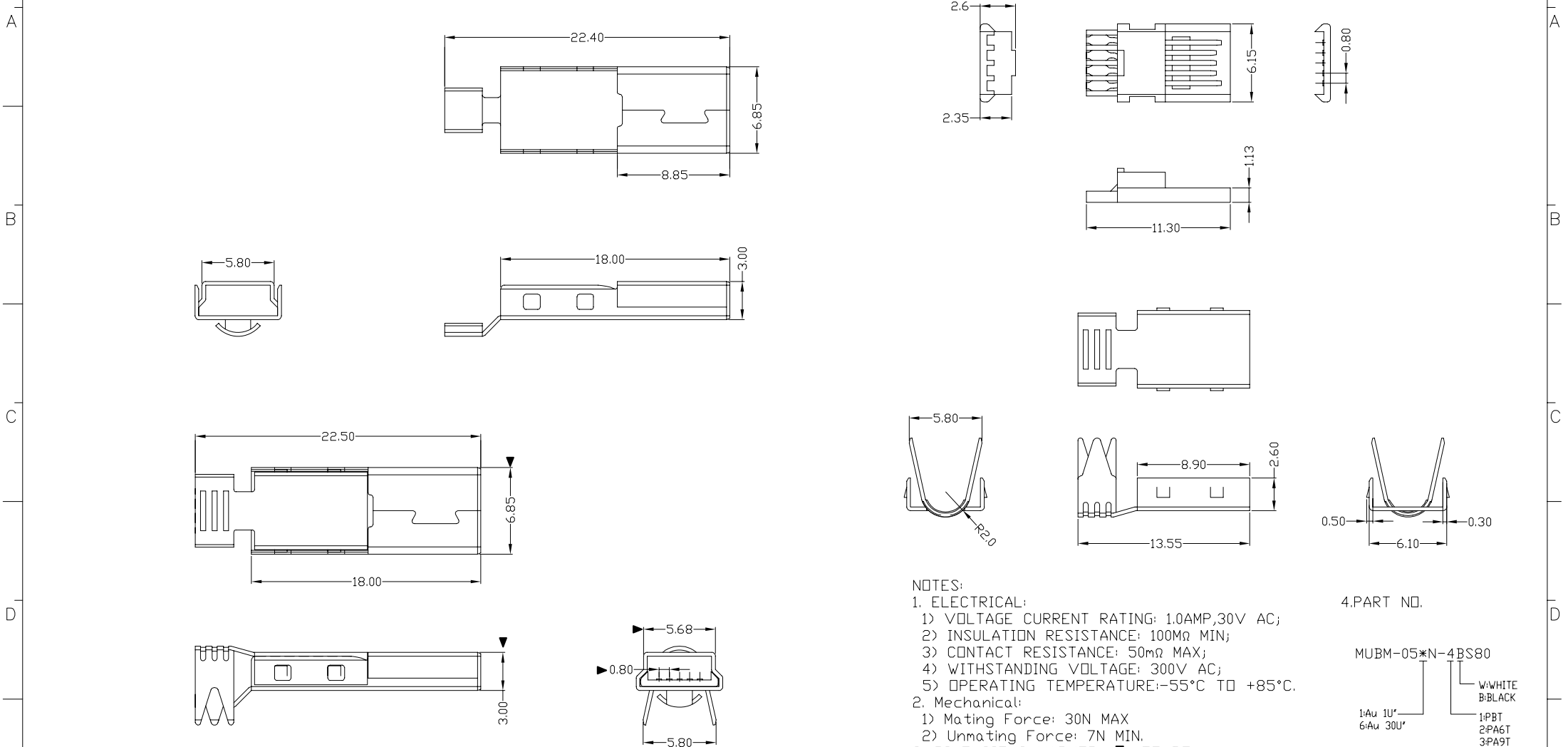

RoHS
Compliant
2002/95/EC

REV	LTR	DESCRIPTION	DATE	REVISER	APPD



NOTES:

- ELECTRICAL:
 - VOLTAGE CURRENT RATING: 1.0AMP,30V AC;
 - INSULATION RESISTANCE: 100MΩ MIN;
 - CONTACT RESISTANCE: 50mΩ MAX;
 - WITHSTANDING VOLTAGE: 300V AC;
 - OPERATING TEMPERATURE:-55°C TO +85°C.
- Mechanical:
 - Mating Force: 30N MAX
 - Unmating Force: 7N MIN.
- DIMENSIONS MARKED "▼" TO BE CHECKED BY Q.C & IPQC.

4.PART NO.

MUBM-05*N-4BS80
 1Au 1U*
 6Au 30U*
 W/WHITE
 B/BLACK
 1PBT
 2PA6T
 3PA9T
 4LCP

Bill of materials:

NO	PARTS	MATERIAL	QTY	FINISHING															
4	HOUSING	LCP	1	UL94V-0	X. ±0.35	X.' ±2*	UNITS	mm	雅安科技有限公司 ACCURATE INNOTECH INC. TITLE: MINT USB 5P/M (超薄B型前五后四) (弹线式 三件套) PART NO.: MUBM-05*N-4BS80 DWG NO.: AII-S80 DR: gan 2012/07/03 CHKD: gan 2012/07/03 APPD:										
3	UP SHELL	SPCC	1	PLATED NICKEL	.X ±0.3	.X' ±1*	MAT'L	SEE NOTE											
2	DOWN SHELL	SPCC	1	PLATED NICKEL	.XX ±0.25	.XX*	FINISH	SEE NOTE											
1	TERMINAL	COPPER ALLOY	5	PLATED GOLD/TIN	.XXX ±0.15	.XXX*	Q'TY	SEE NOTE											
NO	PARTS	MATERIAL	QTY	FINISHING	THESE DRAWINGS AND SPECIFICATIONS ARE THE PROPERTY OF ACCURATE INNOTECH INC AND SHALL NOT BE REPRODUCED, COPIED OR USED IN ANY MANNER WITHOUT THE PRIOR WRITTEN CONSENT OF ACCURATE INNOTECH INC.														