

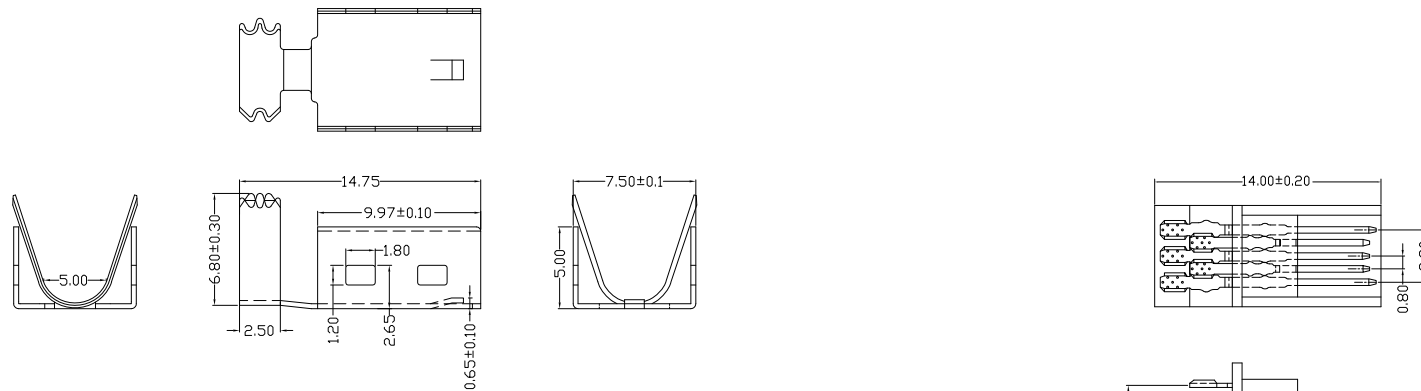

RoHS
Compliant
2002/95/EC

REV.	ECN.	NO.	APPD.



前五后五

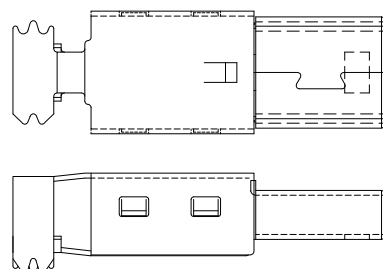
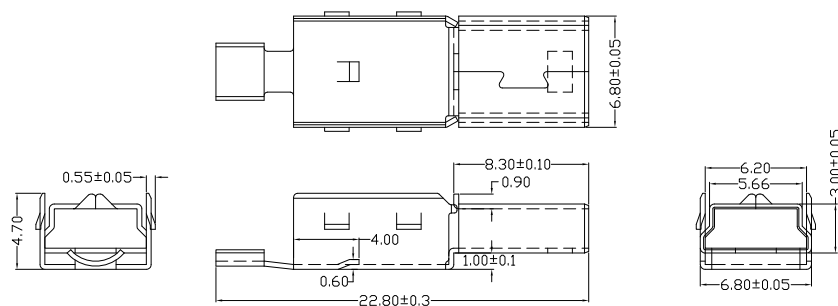

NOTES:

- ELECTRICAL:
 - VOLTAGE CURRENT RATING: 1.0AMP,30V AC;
 - INSULATION RESISTANCE: 100MΩ MIN;
 - CONTACT RESISTANCE: 50mΩ MAX;
 - WITHSTANDING VOLTAGE: 300V AC;
 - OPERATING TEMPERATURE:-55°C TO +85°C.
- Mechanical:
 - Mating Force: 30N MAX
 - Unmating Force: 7N MIN.
- DIMENSIONS MARKED "▼" TO BE CHECKED BY Q.C & IPQC.

4.PART NO.

MUBM-05*N-4BS87

1:Au 1U*
6:Au 30U*

W:WHITE
B:BLACK
1:PB
2:PA6T
3:PA9T
4:LCP

Bill of materials:

NO	PARTS	MATERIAL	QTY	FINISHING	X. ±0.35	X.' ±2'	UNITS
4	HOUSING	LCP	1	UL94V-0	.X ±0.3	.X' ±1'	mm
3	UP SHELL	SPCC	1	PLATED NICKEL	.XX ±0.25	.XX'	SEE NOTE
2	DOWN SHELL	SPCC	1	PLATED NICKEL	.XXX ±0.15	.XXX'	SEE NOTE
1	TERMINAL	COPPER ALLOY	5	PLATED GOLD/TIN	THESE DRAWINGS AND SPECIFICATIONS ARE THE PROPERTY OF ACCURATE INNOTECH INC AND SHALL NOT BE REPRODUCED, COPIED OR USED IN ANY MANNER WITHOUT THE PRIOR WRITTEN CONSENT OF ACCURATE INNOTECH INC.		

雅安科技有限公司
ACCURATE INNOTECH INC.

TITLE: MINI USB 5P/M 普通B型前五后五 (焊线式 三件套)
PART NO.: MUBM-05*N-4BS87

DR: Ricky 2020/04/20
DWG NO.: AII-S87

CHKD: Ricky 2020/04/20
SCALE: 1:1 SHEET: 1/1 REV: B CUSTOMER DRAWING

APPD: