

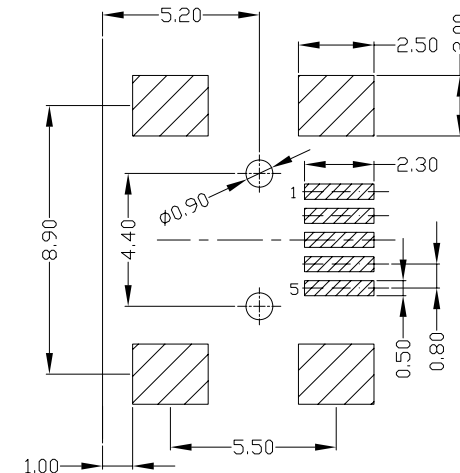

RoHS
Compliant
2002/95/EC

REV.	ECN. NO.	APPD.

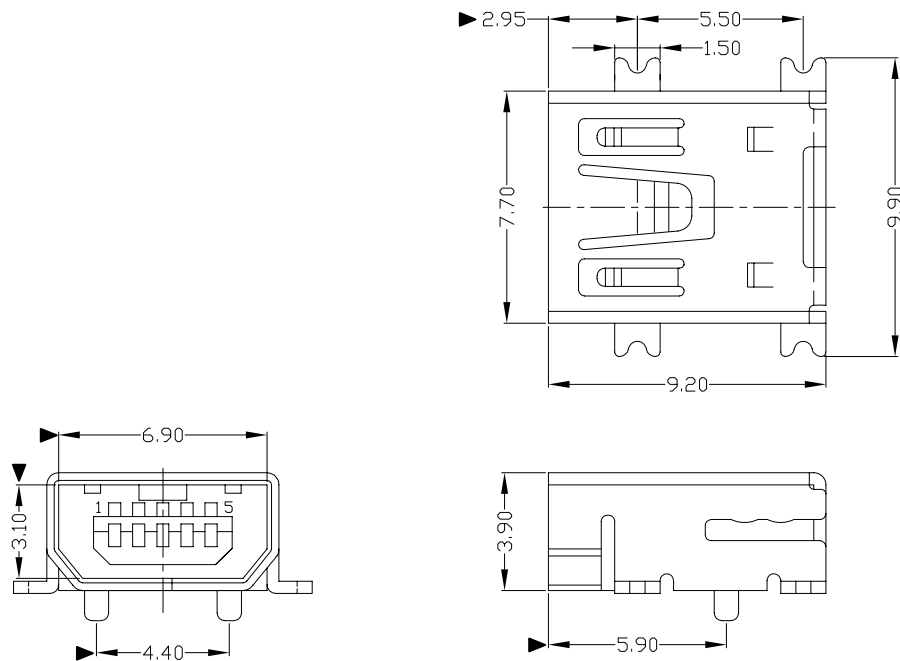

RECOMMENDED PCB LAYOUT

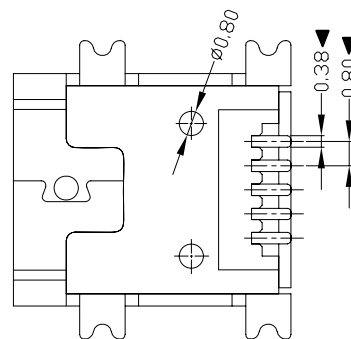

NOTES:

1. ELECTRICAL:

- 1) VOLTAGE CURRENT RATING: 1.0AMP,30V AC;
- 2) INSULATION RESISTANCE: 100M Ω MIN;
- 3) CONTACT RESISTANCE: 50m Ω MAX;
- 4) WITHSTANDING VOLTAGE: 300V AC;
- 5) OPERATING TEMPERATURE:-55°C TO +85°C.

2. Mechanical:

- 1) Mating Force: 30N MAX
- 2) Unmating Force: 7N MIN.

3. DIMENSIONS MARKED "▼" TO BE CHECKED BY Q.C & IPQC.

4.PART NO.

MUNF-05*N-4BH82

1:Au 1U*
6:Au 30U*

W:WHITE
B:BLACK

1:PBT
2:PA6T
3:PA9T
4:LCP

Bill of materials:

NO	PARTS	MATERIAL	QTY	FINISHING	UNITS	mm	雅安科技有限公司 ACCURATE INNOTECH INC.				
3	HOUSING	LCP	1	UL94V-0	X. ± 0.35	X.* $\pm 2^*$	TITLE:	MINI USB 5P/F SMT (AB型双卡点1.0柱)			
2	SHELL	COPPER ALLOY	1	PLATED NICKEL	.X ± 0.3	.X.* $\pm 1^*$	MAT'L	PART NO.:			
1	TERMINAL	COPPER ALLOY	5	PLATED GOLD/TIN	.XX ± 0.25	.XX*	SEE NOTE	MUNF-05*N-4BH82			
					.XXX ± 0.15	.XXX*	FINISH	DWG NO.:			
					THESE DRAWINGS AND SPECIFICATIONS ARE THE PROPERTY OF ACCURATE INNOTECH INC AND SHALL NOT BE REPRODUCED, COPIED OR USED IN ANY MANNER WITHOUT THE PRIOR WRITTEN CONSENT OF ACCURATE INNOTECH INC.		SEE NOTE	AII-H82			
					Q'TY		DR:	gan 2012/7/02			
							CHKD:	gan 2012/7/02			
							APPD:	SCALE SHEET REV. CUSTOMER DRAWING			
								1:1	1/1	B	