

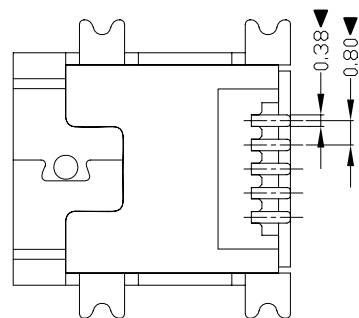

RoHS
Compliant
2002/95/EC

REV.	ECN.	NO.	APPD.

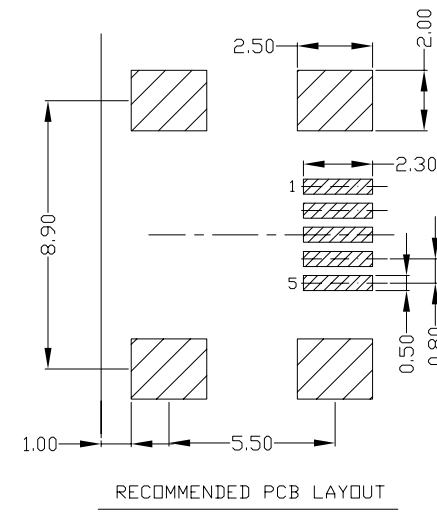
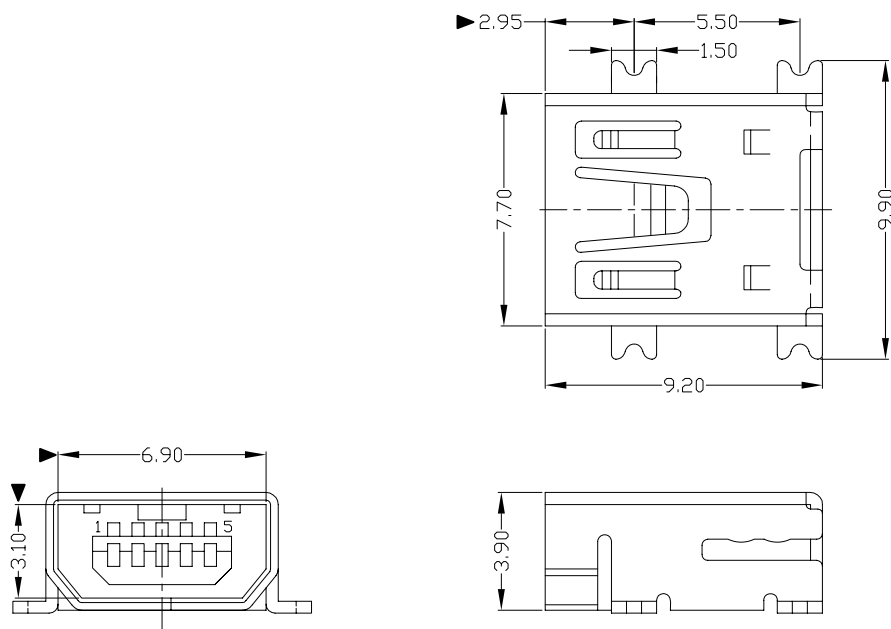

NOTES:

- ELECTRICAL:
 - VOLTAGE CURRENT RATING: 1.0AMP,30V AC;
 - INSULATION RESISTANCE: 100MΩ MIN;
 - CONTACT RESISTANCE: 50mΩ MAX;
 - WITHSTANDING VOLTAGE: 300V AC;
 - OPERATING TEMPERATURE:-55°C TO +85°C.
- Mechanical:
 - Mating Force: 30N MAX
 - Unmating Force: 7N MIN.
- DIMENSIONS MARKED "▼" TO BE CHECKED BY Q.C & IPQC.

4.PART NO.

MUNF-05*N-4BH85

1:Au 1U"
6:Au 30U"

W:WHITE
B:BLACK
1:PBT
2:PA6T
3:PA9T
4:LCP

Bill of materials:

NO	PARTS	MATERIAL	QTY	FINISHING	X. ±0.35	X.' ±2°	UNITS
3	HOUSING	LCP	1	UL94V-0	.X ±0.3	.X' ±1°	mm
2	SHELL	COPPER ALLOY	1	PLATED NICKEL	.XX ±0.25	.XX°	SEE NOTE
1	TERMINAL	COPPER ALLOY	5	PLATED GOLD/TIN	.XXX ±0.15	.XXX°	SEE NOTE
NO	PARTS	MATERIAL	QTY	FINISHING	<small>THESE DRAWINGS AND SPECIFICATIONS ARE THE PROPERTY OF ACCURATE INNOTECH INC AND SHALL NOT BE REPRODUCED, COPIED OR USED IN ANY MANNER WITHOUT THE PRIOR WRITTEN CONSENT OF ACCURATE INNOTECH INC.</small>		

雅安科技有限公司
ACCURATE INNOTECH INC.

TITLE: MINI USB 5P/F SMT (AB型双卡点无柱)	PART NO.: MUNF-05*N-4BH85
DR: gan 2012/7/02	DWG NO.: AII-H85
CHKD: gan 2012/7/02	SCALE: 1:1
APPD:	SHEET: 1/1
	REV: B
	CUSTOMER DRAWING