

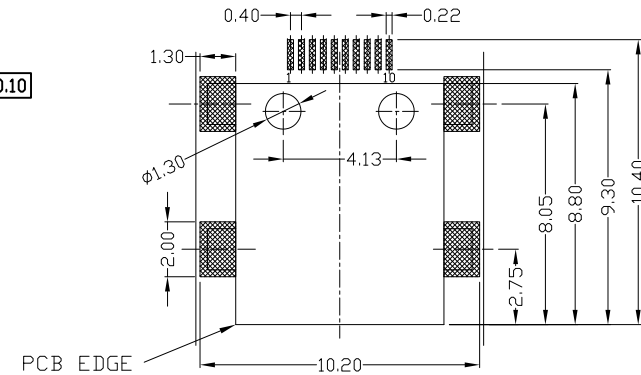

RoHS
Compliant
2002/95/EC

REV.	ECN.	NO.	APPD.

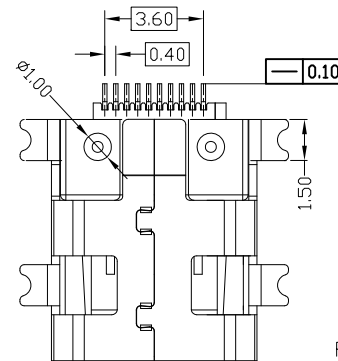
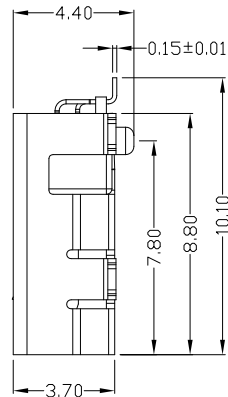
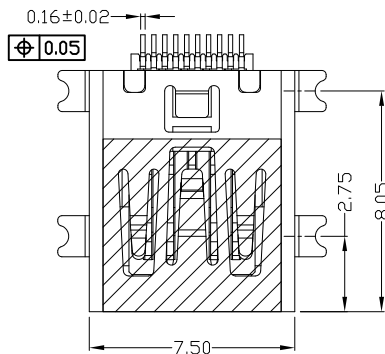
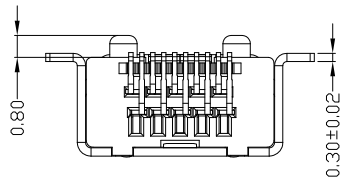

RECOMMENDED PCB LAYOUT

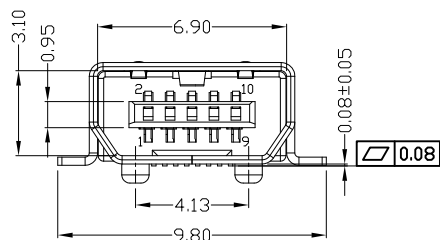

NOTES:

- ELECTRICAL:
 - VOLTAGE CURRENT RATING: 1.0AMP,100V AC;
 - INSULATION RESISTANCE: 100MΩ MIN;
 - CONTACT RESISTANCE: 50mΩ MAX;
 - WITHSTANDING VOLTAGE: 100V AC;
 - OPERATING TEMPERATURE:-30°C TO +80°C.
- Mechanical:
 - Mating Force: 35N MAX
 - Unmating Force: 7N MIN.
 - Durability: 5,000 cycles
- DIMENSIONS MARKED "▼" TO BE CHECKED BY Q.C & IPQC.

4.PART NO.

MUNF-101T-4BVUA122-M

1:AU 1U"
6:AU 30U"

W:WHITE
B:BLACK
1:PBT
2:PA6T
3:PA9T
4:LCP

Bill of materials:

NO	PARTS	MATERIAL	QTY	FINISHING
3	HOUSING	LCP+30%GF	1	UL94V-0
2	SHELL	COPPER ALLOY	1	PLATED TIN
1	TERMINAL	COPPER ALLOY	10	PLATED GOLD

THESE DRAWINGS AND SPECIFICATIONS ARE THE PROPERTY OF ACCURATE INNOTECH INC AND SHALL NOT BE REPRODUCED, COPIED OR USED IN ANY MANNER WITHOUT THE PRIOR WRITTEN CONSENT OF ACCURATE INNOTECH INC.

UNITS mm			
.X ±0.15	.X* ±1*	MAT'L	SEE NOTE
.XX ±0.10	.XX*	FINISH	SEE NOTE
.XXX ±0.05	.XXX*	Q'TY	SEE NOTE

雅安科技有限公司
ACCURATE INNOTECH INC.

TITLE:		PART NO.:	
MINI USB 10PIN PHILIPS 母座有柱贴麦拉全贴型		MUNF-101T-4BVUA122-M	
DR: Ricky 2020/11/27		DWG NO.:	
CHKD: Ricky 2020/11/27		AII-VUA122-M	
APPD:	SCALE	SHEET	REV.
	4:1	1/1	B
			CUSTOMER DRAWING