

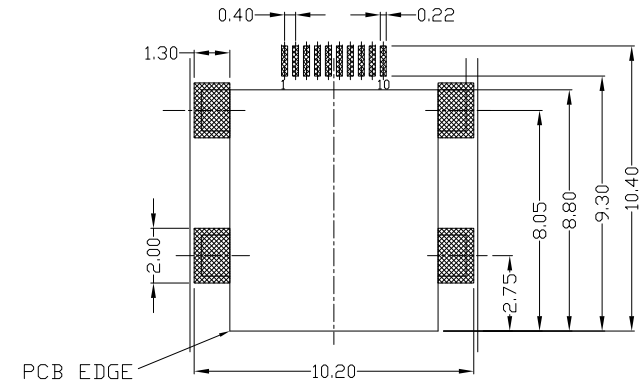

RoHS
Compliant
2002/95/EC

| REV. | ECN. NO. | APPD. |
|------|----------|-------|
| | | |
| | | |

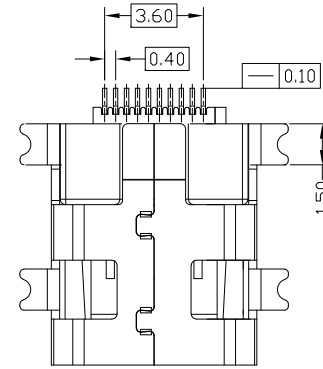
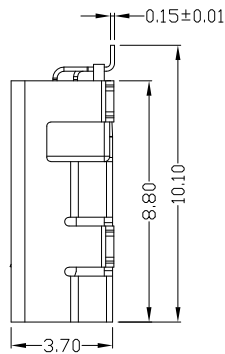
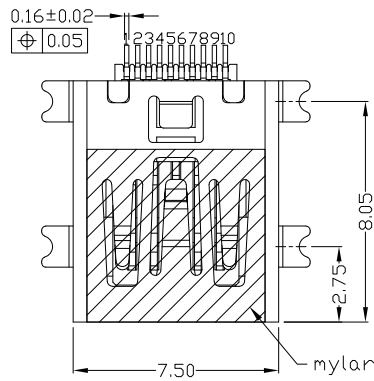
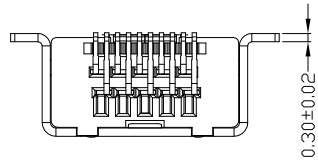

RECOMMENDED PCB LAYOUT

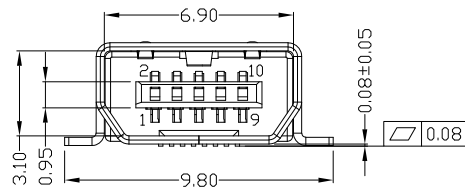

NOTES:

- ELECTRICAL:
 - VOLTAGE CURRENT RATING: 1.0AMP,100V AC;
 - INSULATION RESISTANCE: 100MΩ MIN;
 - CONTACT RESISTANCE: 50mΩ MAX;
 - WITHSTANDING VOLTAGE: 100V AC;
 - OPERATING TEMPERATURE:-30°C TO +80°C.
- Mechanical:
 - Mating Force: 35N MAX
 - Unmating Force: 7N MIN.
 - Durability: 5,000 cycles
- DIMENSIONS MARKED "▼" TO BE CHECKED BY Q.C & IPQC.

4.PART NO.
MUNF-101T-4BVUA333-M
W:WHITE
B:BLACK
1:Au 1U"
6:Au 30U"

Bill of materials:

| | | | | | | | |
|----|----------|--------------|-----|-----------------|------------|---------|----------|
| 3 | HOUSING | LCP+30%GF | 1 | UL94V-0 | .X ±0.15 | .X* ±1* | UNITS mm |
| 2 | SHELL | COPPER ALLOY | 1 | PLATED TIN | .XX ±0.10 | .XX* | MAT'L |
| 1 | TERMINAL | COPPER ALLOY | 10 | PLATED GOLD/TIN | .XXX ±0.05 | .XXX* | SEE NOTE |
| NO | PARTS | MATERIAL | QTY | FINISHING | SEE NOTE | | |

THESE DRAWINGS AND SPECIFICATIONS ARE THE PROPERTY OF ACCURATE INNOTECH INC AND SHALL NOT BE REPRODUCED, COPIED OR USED IN ANY MANNER WITHOUT THE PRIOR WRITTEN CONSENT OF ACCURATE INNOTECH INC.

| | | | |
|--|--|-----------------------------------|------------------|
| 雅安科技有限公司 ACCURATE INNOTECH INC. | | | |
| TITLE: MINI USB 10PIN PHILIPS 母座无柱贴麦拉全贴型 | | PART NO.: MUNF-101T-4BVUA333-M | |
| DR: Ricky 2021/11/25 | | DWG NO.: AII-VUA333-M | |
| CHKD: Ricky 2021/11/25 | | SCALE | SHEET |
| APPD: | | 4:1 | 1/1 |
| | | REV. | CUSTOMER DRAWING |
| | | B | |