

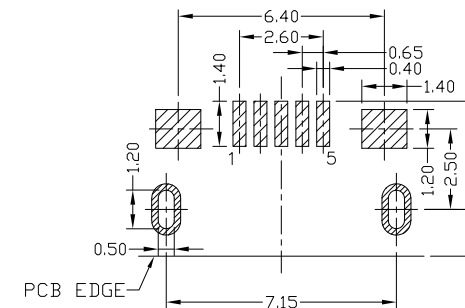

RoHS
Compliant
2002/95/EC

Halogen Free

REV.	ECN. NO.	APPD.

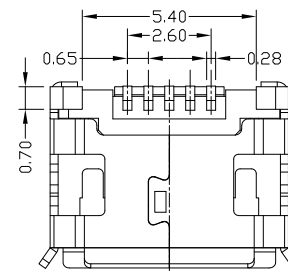
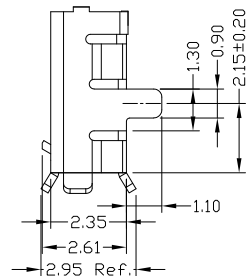
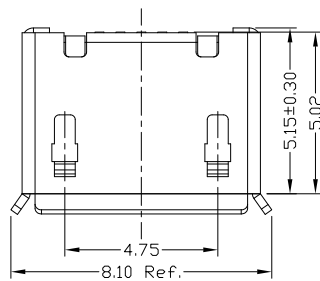
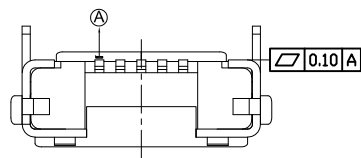

RECOMMENDED PCB LAYOUT

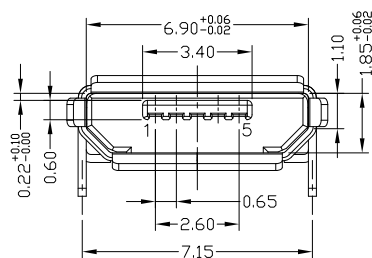

NOTES:

1. ELECTRICAL:

- VOLTAGE CURRENT RATING: PIN1&5 1.8AMP MAX / PIN2&3&4 1AMP MAX. ,30V AC;
- INSULATION RESISTANCE: 100MΩ MIN;
- CONTACT RESISTANCE: 30mΩ MAX;
- WITHSTANDING VOLTAGE: 100V AC; FOR 1 MIN.
- OPERATING TEMPERATURE: -30°C TO +80°C.

2. Mechanical:

- Mating Force: 35N MAX
- Unmating Force: 10N MIN.

3. DIMENSIONS MARKED "▼" TO BE CHECKED BY Q.C & IPQC.

4. PART NO.

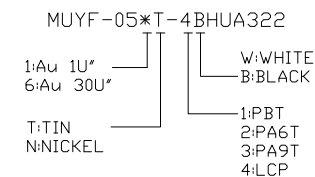

Bill of materials:

NO	PARTS	MATERIAL	QTY	FINISHING	UNITS	mm	TITLE:	PART NO.:
3	SHELL	STAINLESS STEEL	1	PLATED TIN	X. ±0.35	X.' ±2'	雅安科技有限公司 ACCURATE INNOTECH INC.	MUYF-05XT-4BHUA322
2	HOUSING	LCP+30%GF	1	UL94V-0	.X ±0.30	.X' ±1'	MICRO USB B TYPE F 5P 插板7.2 有导位无柱 外壳加焊盘脚长1.1	AII-HUA322
1	TERMINAL	COPPER ALLOY	5	PLATED GOLD	.XX ±0.25	.XX'	DR: Ricky 2018/9/13	DWG NO.:
					.XXX ±0.15	.XXX'	CHKD: Ricky 2018/9/13	SCALE
					THESE DRAWINGS AND SPECIFICATIONS ARE THE PROPERTY OF ACCURATE INNOTECH INC. AND SHALL NOT BE REPRODUCED, COPIED OR USED IN ANY MANNER WITHOUT THE PRIOR WRITTEN CONSENT OF ACCURATE INNOTECH INC.		APPD:	SHEET
								REV.
								CUSTOMER DRAWING