

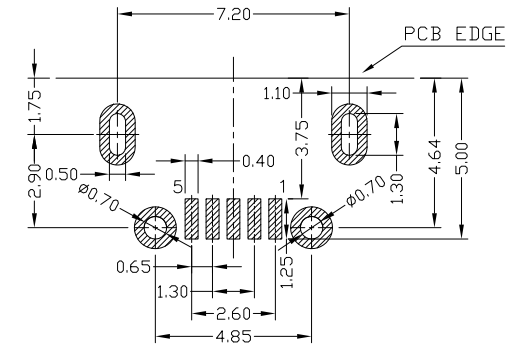

RoHS
Compliant
2002/95/EC

Halogen Free

REV.	ECN. NO.	APPD.

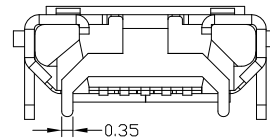
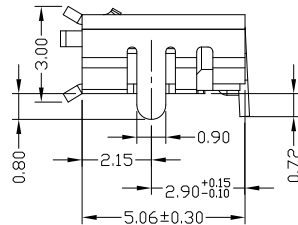
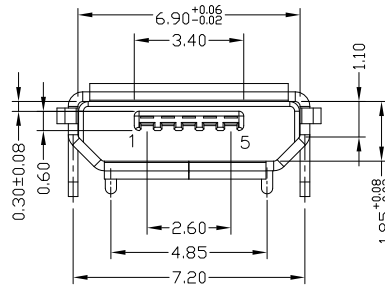
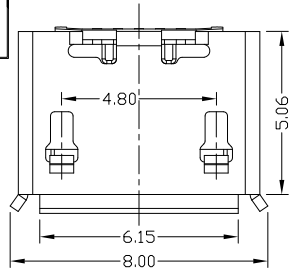

RECOMMENDED PCB LAYOUT

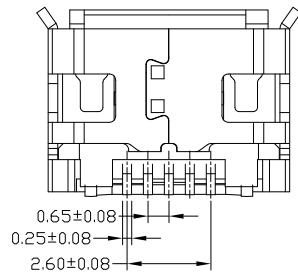

NOTES:

1.ELECTRICAL:

- 1)VOLTAGE CURRENT RATING:PIN1&5 1.8AMP MAX / PIN2&3&4 1AMP MAX. ,30V AC;
- 2)INSULATION RESISTANCE: 100MΩ MIN;
- 3)CONTACT RESISTANCE: 30mΩ MAX;
- 4)WITHSTANDING VOLTAGE: 100V AC; FOR 1 MIN.
- 5)OPERATING TEMPERATURE:-30°C TO +80°C.

2.Mechanical:

- 1)Mating Force: 35N MAX
- 2)Unmating Force: 10N MIN.

3.DIMENSIONS MARKED "▼" TO BE CHECKED BY Q.C & IPQC.

4.PART NO.

MUYF-05*T-4BHUA409

1:Au 1U"
6:Au 30U"
T:TIN
N:NICKEL

W:WHITE
B:BLACK

1:PBT
2:PA6T
3:PA9T
4:LCP

Bill of materials:

NO	PARTS	MATERIAL	QTY	FINISHING	UNITS	mm	雅安科技有限公司 ACCURATE INNOTECH INC.				
3	SHELL	STAINLESS STEEL / COPPER ALLOY	1	PLATED TIN	X. ±0.35	X.' ±2'	MAT'L	TITLE: MIRCO USB B TYPE F 5P 四脚全插牛角短针斜后盖0.8版		PART NO.: MUYF-05*T-4BHUA409	
2	HOUSING	LCP+30%GF	1	UL94V-0	.X ±0.30	.X' ±1'	SEE NOTE	DR: Ricky 2018/4/30		DWG NO.: AII-HUA409	
1	TERMINAL	COPPER ALLOY	5	PLATED GOLD	.XX ±0.25	.XX'	SEE NOTE	CHKD: Ricky 2018/4/30		SCALE SHEET REV. CUSTOMER DRAWING	
					.XXX ±0.15	.XXX'	Q'TY	APPD:		5:1 1/1 A	

THESE DRAWINGS AND SPECIFICATIONS ARE THE PROPERTY OF ACCURATE INNOTECH AND SHALL NOT BE REPRODUCED, COPIED OR USED IN ANY MANNER WITHOUT THE PRIOR WRITTEN CONSENT OF ACCURATE INNOTECH INC

