

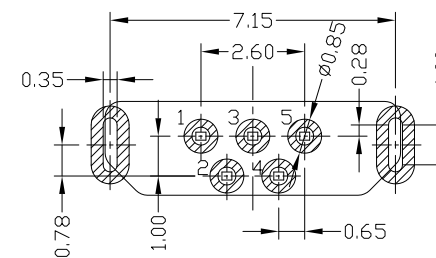

RoHS
Compliant
2002/95/EC

Halogen Free

REV.	ECN. NO.	APPD.

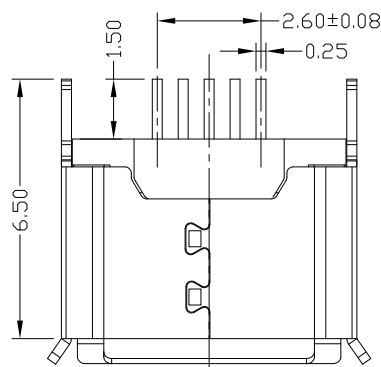
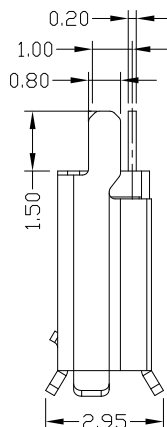
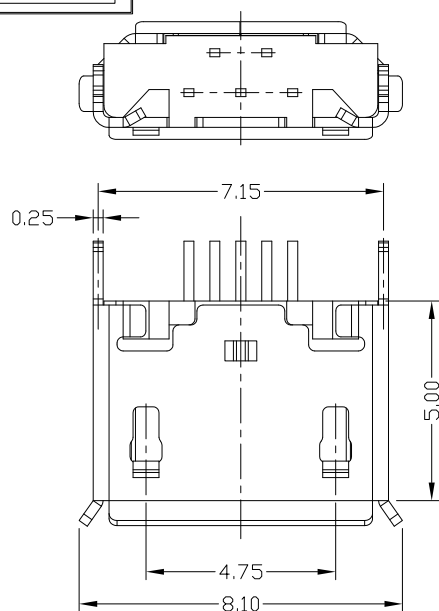

RECOMMENDED PCB LAYOUT

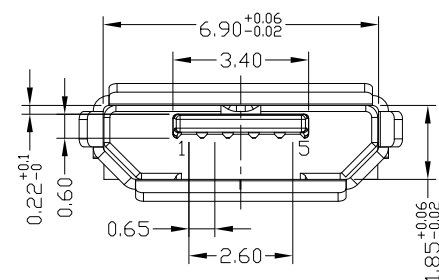

NOTES:

1.ELECTRICAL:

- VOLTAGE CURRENT RATING: PIN1&5 1.8AMP MAX / PIN2&3&4 1AMP MAX. ,30V AC;
- INSULATION RESISTANCE: 100MΩ MIN;
- CONTACT RESISTANCE: 30mΩ MAX;
- WITHSTANDING VOLTAGE: 100V AC; FOR 1 MIN.
- OPERATING TEMPERATURE: -30°C TO +80°C.

2.Mechanical:

- Mating Force: 35N MAX
- Unmating Force: 10N MIN.

3.DIMENSIONS MARKED "▼" TO BE CHECKED BY Q.C & IPQC.

4.PART NO.

MUYF-05*T-4BP UA678

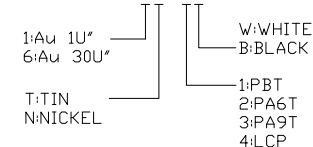

Bill of materials:

NO	PARTS	MATERIAL	QTY	FINISHING	UNITS	mm	TITLE:	PART NO.:	DR:	CHKD:	APPD:	SCALE	SHEET	REV.	CUSTOMER DRAWING
3	SHELL	STAINLESS STEEL	1	PLATED TIN	X. ±0.35	X.' ±2'	MICRO USB B TYPE F 5P 180度 插板脚长1.5	MUYF-05*T-4BP UA678	Ricky	Ricky		1:1	1/1	A	
2	HOUSING	LCP+30%GF	1	UL94V-0	.X ±0.30	.X' ±1'									
1	TERMINAL	COPPER ALLOY	5	PLATED GOLD	.XX ±0.25	.XX'									
					.XXX ±0.15	.XXX'									
					THESE DRAWINGS AND SPECIFICATIONS ARE THE PROPERTY OF ACCURATE INNOTECH AND SHALL NOT BE REPRODUCED, COPIED OR USED IN ANY MANNER WITHOUT THE PRIOR WRITTEN CONSENT OF ACCURATE INNOTECH INC										

雅安科技有限公司
ACCURATE INNOTECH INC.

DR: Ricky 2018/3/27
CHKD: Ricky 2018/3/27
APPD:
SCALE: 1:1
SHEET: 1/1
REV: A
CUSTOMER DRAWING