

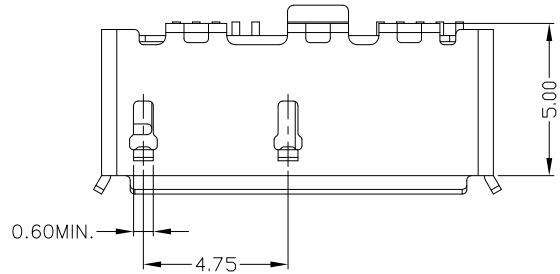

RoHS
Compliant
2002/95/EC

REV	LTR	DESCRIPTION	DATE	REVISER	APPD



PIN NUMBER	SIGNAL NAME
1	VBUS
2	D-
3	D+
4	ID
5	GND
6	MICB_SSTX-
7	MICB_SSTX+
8	GND_DRAIN
9	MICB_SSRX-
10	MICB_SSRX+
Shell	Shield

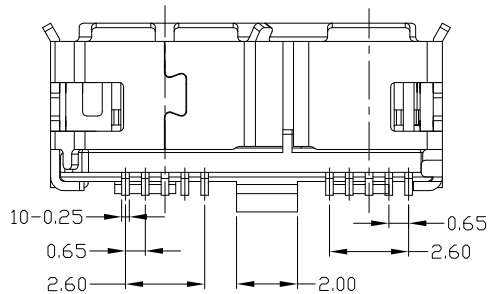
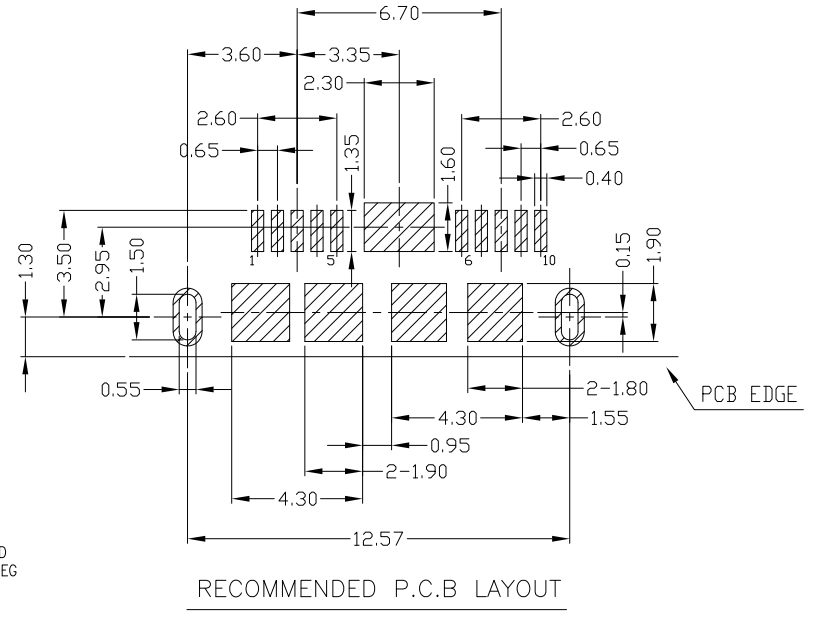
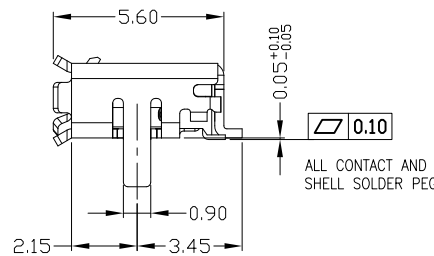
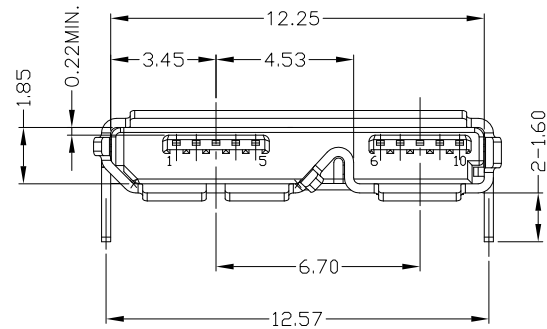

NOTES:

- ELECTRICAL:
 - VOLTAGE CURRENT RATING: 1AMP, 30V AC;
 - INSULATION RESISTANCE: 100MΩ MIN;
 - CONTACT RESISTANCE: 30mΩ MAX;
 - WITHSTANDING VOLTAGE: 500V AC;
 - OPERATING TEMPERATURE: -40°C TO +85°C.
- Mechanical:
 - Mating Force: 35N MAX
 - Unmating Force: 10N MIN.
- DIMENSIONS MARKED "▼" TO BE CHECKED BY Q.C & IPQC.

4. PART NO.

MUYF-10*N-4BHW07
 1:Au 1U"
 5:Au 15U"
 6:Au 30U"
 W:WHITE
 B:BLACK
 1PBT
 2PA6T
 3PA9T
 4LCP

Bill of materials:

NO	PARTS	MATERIAL	QTY	FINISHING	X. ±0.35	X.' ±2'	UNITS	mm	雅安科技有限公司 ACCURATE INNOTECH INC.							
3	SHELL	STAINLESS STEEL	1	PLATED NICKEL	.X ±0.3	.X' ±1'	MAT'L	SEE NOTE	TITLE: MICRO USB 3.0 B TYPE F 带SMT型加强脚 脚长1.60mm脚距12.57mm PART NO.: MUYF-10*N-4BHW07							
2	HOUSING	LCP+30%GF	1	UL94V-0	.XX ±0.25	.XX'	FINISH	SEE NOTE					DR: gan 2017/08/06			
1	TERMINAL	COPPER ALLOY	10	PLATED GOLD/TIN	.XXX ±0.15	.XXX'	Q'TY	SEE NOTE					CHKD: gan 2017/08/06			
THESE DRAWINGS AND SPECIFICATIONS ARE THE PROPERTY OF ACCURATE INNOTECH INC AND SHALL NOT BE REPRODUCED, COPIED OR USED IN ANY MANNER WITHOUT THE PRIOR WRITTEN CONSENT OF ACCURATE INNOTECH INC									SCALE	SHEET	REV.	CUSTOMER DRAWING				
									1:1	1/1	B	DRAWING				