

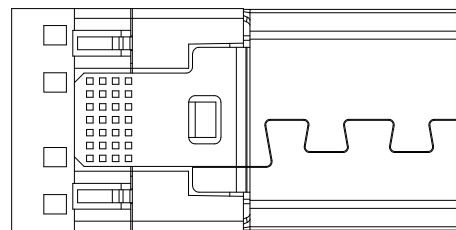

RoHS
Compliant
2002/95/EC

REV.	ECN.	NO.	APPD.

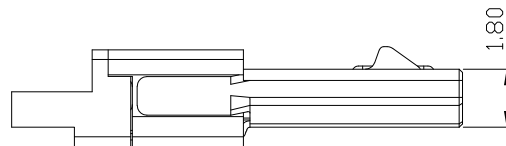
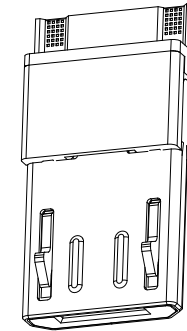
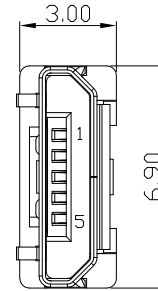
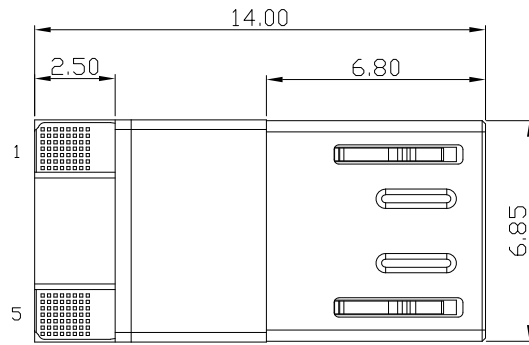

NOTES:

- ELECTRICAL:
 - VOLTAGE CURRENT RATING: 1.5AMP,30V AC;
 - INSULATION RESISTANCE: 100MΩ MIN;
 - CONTACT RESISTANCE: 30mΩ MAX;
 - WITHSTANDING VOLTAGE: 100V AC;
 - OPERATING TEMPERATURE: -25°C TO +85°C.
- Mechanical:
 - Mating Force: 35N MAX
 - Unmating Force: 8N MIN.
- DIMENSIONS MARKED "▼" TO BE CHECKED BY Q.C & IPQC.

4.PART NO.

MUYM-051N-4BSD01

W:WHITE
B:BLACK

1:Au 1U"
6:Au 30U"

1:PBT
2:PA6T
3:PA9T
4:LCP

Bill of materials:

NO	PARTS	MATERIAL	QTY	FINISHING
5	TERMINAL	COPPER ALLOY	5	PLATED GOLD/TIN
4	SPRING	STAINLESS STEEL	2	
3	SHELL	STAINLESS STEEL	1	PLATED NICKEL
2	MOLDING	LCP+30%GF	1	UL94V-0
1	HOUSING	LCP+30%GF	1	UL94V-0

X.	±0.25	X.*	±3*
.X	±0.15	.X*	
.XX	±0.08	.XX*	
.XXX	±0.03	.XXX*	

THESE DRAWINGS AND SPECIFICATIONS ARE THE PROPERTY OF ACCURATE INNOTECH INC AND SHALL NOT BE REPRODUCED, COPIED OR USED IN ANY MANNER WITHOUT THE PRIOR WRITTEN CONSENT OF ACCURATE INNOTECH INC

UNITS	mm	雅安科技有限公司 ACCURATE INNOTECH INC.			
MAT'L	SEE NOTE				
FINISH	SEE NOTE	TITLE:	PART NO.:		
Q'TY		MICRO USB BM 一排焊线式 前五后二短体 T=3.0	MUYM-051N-4BSD01		
		DR: Ricky 2019/11/05	DWG NO.:		
		CHKD: Ricky 2019/11/05	AII-SD01		
		APPD:	SCALE	SHEET	REV.
			1:1	1/1	A
			CUSTOMER DRAWING		