

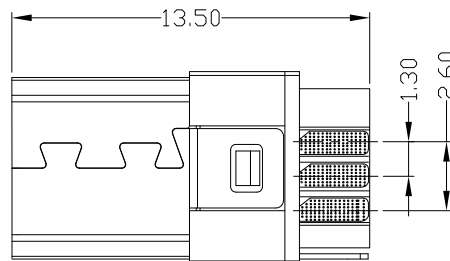

RoHS  
Compliant  
2002/95/EC

| REV. | ECN. | NO. | APPD. |
|------|------|-----|-------|
|      |      |     |       |
|      |      |     |       |
|      |      |     |       |

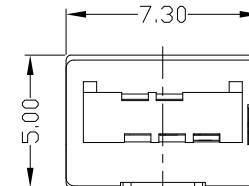
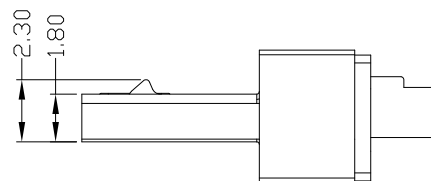
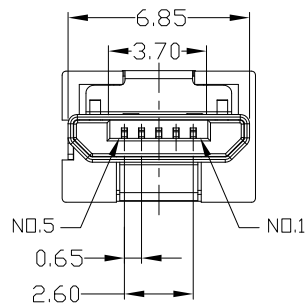
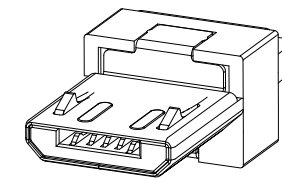
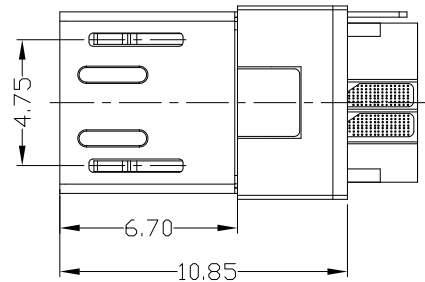

- NOTES:
- ELECTRICAL:
    - VOLTAGE CURRENT RATING: 1.5AMP,100V AC;
    - INSULATION RESISTANCE: 100MΩ MIN;
    - CONTACT RESISTANCE: 30mΩ MAX;
    - WITHSTANDING VOLTAGE: 250V AC;
    - OPERATING TEMPERATURE:-30°C TO +85°C.
  - Mechanical:
    - Mating Force: 35N MAX
    - Unmating Force: 10N MIN.
  - DIMENSIONS MARKED "▼" TO BE CHECKED BY Q.C & IPQC.
  - PART NO.

MUYM-051N-4BSS14

1:Au 1U\*  
6:Au 30U\*  
W:WHITE  
B:BLACK  
1:PB  
2:PA6T  
3:PA9T  
4:LCP

Bill of materials:

|    |          |                   |     |                 |  |         |        |          |  |
|----|----------|-------------------|-----|-----------------|--|---------|--------|----------|--|
| 4  | HOOK     | STAINLESS STEEL   | 1   |                 | X. ±0.3  | X.* ±2* | UNITS  | mm       | <p>雅安科技有限公司<br/>ACCURATE INNOTECH INC.</p> <p>TITLE: MICRO 5P B公焊线一体式 H5.0</p> <p>PART NO.: MUYM-051N-4BSS14</p> <p>DR: gan 2015/12/08</p> <p>DWG NO.: AII-SS14</p> <p>CHKD: gan 2015/12/08</p> <p>APPD:</p> <p>SCALE: 1:1</p> <p>SHEET: 1/1</p> <p>REV: B</p> <p>CUSTOMER DRAWING</p> |
| 3  | HOUSING  | LCP+30%GF         | 1   | UL94V-0         | .X ±0.2  | .X* ±1* | MAT'L  | SEE NOTE |  |
| 2  | SHELL    | COPPER ALLOY/SPCC | 1   | PLATED NICKEL   | .XX ±0.15  | .XX*    | FINISH | SEE NOTE |  |
| 1  | TERMINAL | COPPER ALLOY      | 5   | PLATED GOLD/TIN | .XXX ±0.10   | .XXX*   | Q'TY   |          |  |
| NO | PARTS    | MATERIAL          | QTY | FINISHING       | <p>THESE DRAWINGS AND SPECIFICATIONS ARE THE PROPERTY OF ACCURATE INNOTECH INC AND SHALL NOT BE REPRODUCED, COPIED OR USED IN ANY MANNER WITHOUT THE PRIOR WRITTEN CONSENT OF ACCURATE INNOTECH INC.</p> |         |        |          |  |