

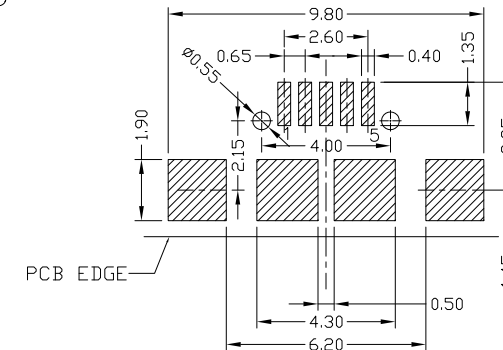

RoHS
Compliant
2002/95/EC

Halogen Free

REV.	ECN. NO.	APPD.

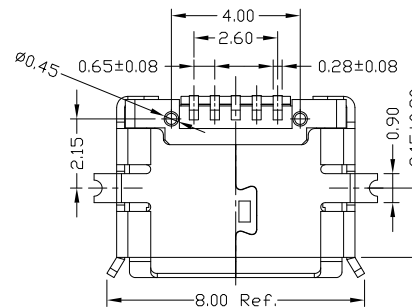
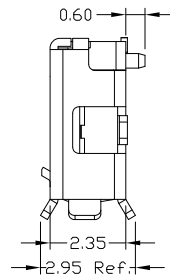
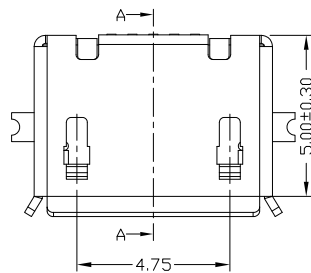
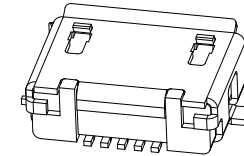
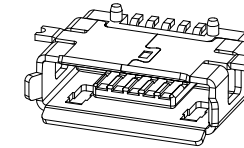
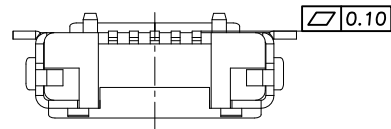

RECOMMENDED PCB LAYOUT

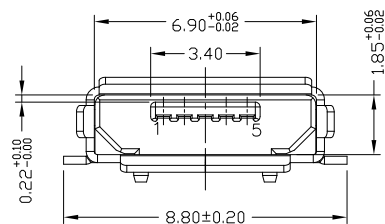

NOTES:

- ELECTRICAL:
 - VOLTAGE CURRENT RATING: PIN1&5 1.8AMP MAX / PIN2&3&4 1AMP MAX. ,30V AC;
 - INSULATION RESISTANCE: 100MΩ MIN;
 - CONTACT RESISTANCE: 30mΩ MAX;
 - WITHSTANDING VOLTAGE: 100V AC; FOR 1 MIN.
 - OPERATING TEMPERATURE: -30°C TO +80°C.
- Mechanical:
 - Mating Force: 35N MAX
 - Unmating Force: 10N MIN.
- DIMENSIONS MARKED "▼" TO BE CHECKED BY Q.C & IPQC.

4.PART NO.

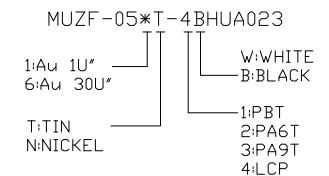

Bill of materials:

NO	PARTS	MATERIAL	QTY	FINISHING	UNITS	mm	雅安科技有限公司 ACCURATE INNOTECH INC.				
3	SHELL	COPPER ALLOY	1	PLATED TIN	X. ±0.35	X.' ±2'	TITLE:	PART NO.:			
2	HOUSING	LCP+30%GF	1	UL94V-0	.X ±0.30	.X' ±1'	MAT'L	MICRO USB AB TYPE F 5P SMT 有脚柱			
1	TERMINAL	COPPER ALLOY	5	PLATED GOLD	.XX ±0.25	.XX'	SEE NOTE	MUZF-05XT-4BHUA023			
					.XXX ±0.15	.XXX'	FINISH	DWG NO.:			
					THESE DRAWINGS AND SPECIFICATIONS ARE THE PROPERTY OF ACCURATE INNOTECH AND SHALL NOT BE REPRODUCED, COPIED OR USED IN ANY MANNER WITHOUT THE PRIOR WRITTEN CONSENT OF ACCURATE INNOTECH INC.		SEE NOTE	AII-HUA023			
					Q'TY		DR:	SCALE SHEET REV. CUSTOMER DRAWING			
							CHKD:	5:1	1/1	A	
							APPD:				