

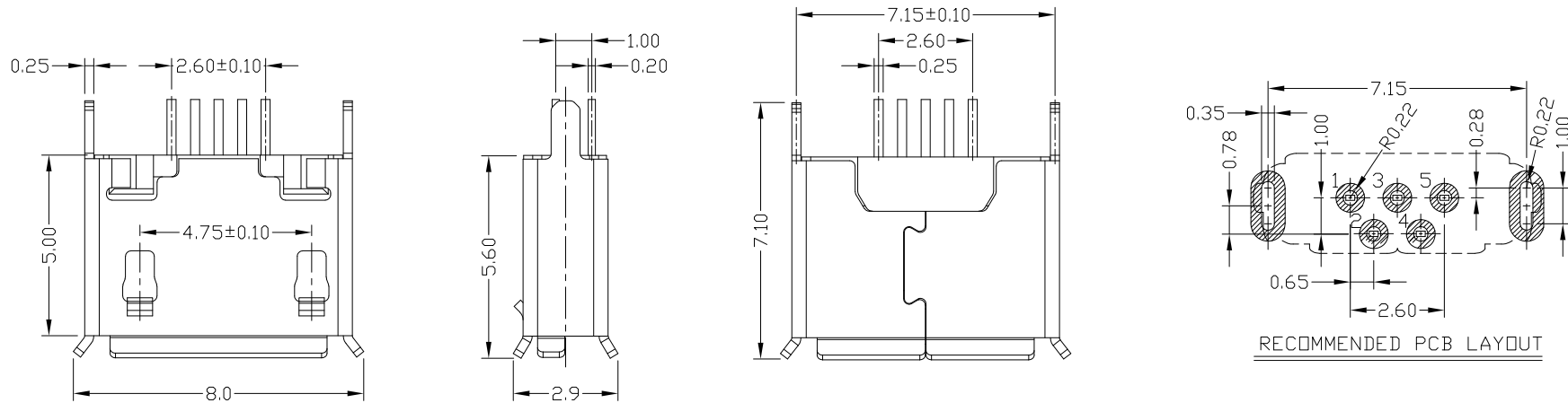

RoHS
Compliant
2002/95/EC

REV.	ECN.	NO.	APPD.



RECOMMENDED PCB LAYOUT

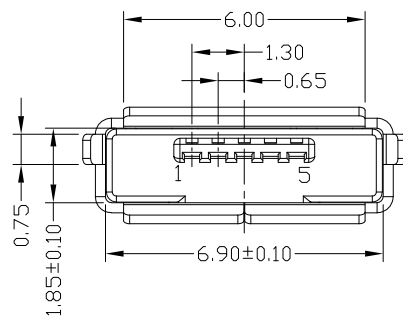

NOTES:

1.ELECTRICAL:

- 1)VOLTAGE CURRENT RATING:1.0AMP MAX. ,30V AC;
- 2)INSULATION RESISTANCE: 100MΩ MIN.
- 3)CONTACT RESISTANCE: 30mΩ MAX; INITIAL;40mΩ MAX.
- 4)WITHSTANDING VOLTAGE: 100V AC MIN.
- 5)OPERATING TEMPERATURE:-30°C TO +80°C.

2.MECHANICAL:

- 1)MATING FORCE: 35N MAX
- 2)UNMATING FORCE: 10N MIN. INITIAL 8~20N AFTER

3.DIMENSIONS MARKED "▼" TO BE CHECKED BY Q.C & IPQC.

4.PART NO.

MUZF-05*T-4BPG3019

1:Au 1U"
6:Au 30U"
T:TIN
N:NICKEL
W:WHITE
B:BLACK
1:PBT
2:PA6T
3:PA9T
4:LCP

Bill of materials:

NO	PARTS	MATERIAL	QTY	FINISHING	UNITS	mm	TITLE:	PART NO.:
3	SHELL	STAINLESS STEEL	1	PLATED TIN	X.	±0.50	X.*	±1*
2	HOUSING	LCP+30%GF	1	UL94V-0	.X	±0.20	.X*	
1	TERMINAL	COPPER ALLOY	5	PLATED NICKEL/GOLD	.XX	±0.10	.XX*	
					.XXX	±0.03	.XXX*	
					THESE DRAWINGS AND SPECIFICATIONS ARE THE PROPERTY OF ACCURATE INNOTECH AND SHALL NOT BE REPRODUCED, COPIED OR USED IN ANY MANNER WITHOUT THE PRIOR WRITTEN CONSENT OF ACCURATE INNOTECH INC			
					Q'TY		DR: Ricky 2022/12/20	DWG NO.:
							CHKD: Ricky 2022/12/20	AII-PG3019
							APPD:	SCALE SHEET REV. CUSTOMER DRAWING
								1:1 1/1 A

雅安科技有限公司
ACCURATE INNOTECH INC.

TITLE: MICRO USB AB TYPE F 5P
180度 插板脚长1.5

PART NO.: MUZF-05XT-4BPG3019

DWG NO.: AII-PG3019

SCALE SHEET REV. CUSTOMER DRAWING
1:1 1/1 A