

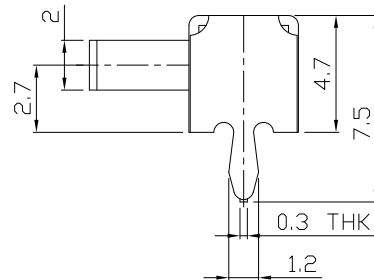

RoHS  
Compliant  
2002/95/EC

REV.	ECN.	NO.	APPD.

DIMENSIONS

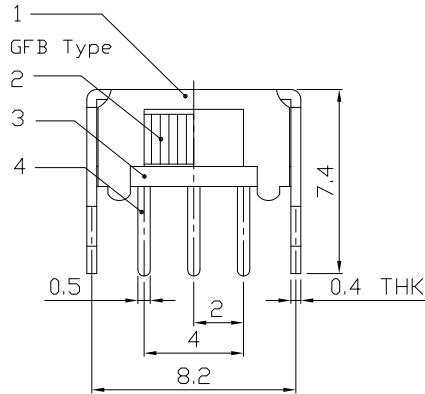
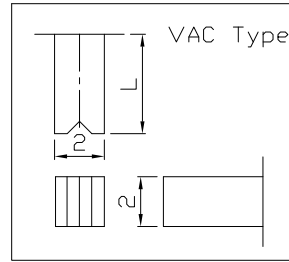
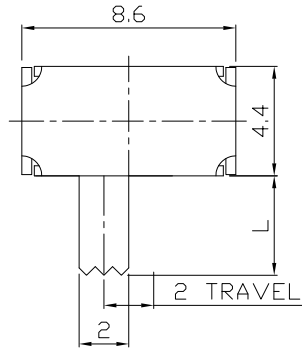

MODEL CODE

SK-12D12- GFB

Knob Type
GFB
VAC

L(mm)
~

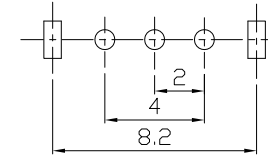

P.C.B LAYOUT  
BOTTOM VIEW

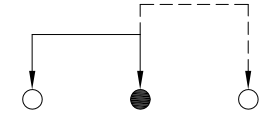

CIRCUIT DIAGRAM

ELECTRO-MECHANICAL CHARACTERISTICS  
Refer to additional specifications

RATING	0.3A 50V DC
CIRCUIT	1P2T
CONTACT RESISTANCE	100mΩ MAX.
TIMING	SHORTING
TRAVEL	2mm
OPERATING FORCE	250±100gf
OPERATING LIFE(cycles)	10,000

8					
7					
6	SPRING PLATE	SUS	1	Ag PLATED	
5	CONTACT CLIP	PBS STRIP	1	Ag PLATED	
4	TERMINAL	BRASS STRIP	3	Ag PLATED	
3	BASE	PHENOLIC RESIN	1	NATURAL	
2	KNOB	POM	1	BLACK	
1	FRAME	STEEL STRIP	1	Ni PLATED	
NO.	PARTS	MATERIAL	Q'TY	FINISHING	

WITHIN 1.5mm: ±0.1mm  
OVER 1.5mm: ±0.2mm

UNITS mm

MAT'L SEE NOTE

FINISH SEE NOTE

Q'TY

THESE DRAWINGS AND SPECIFICATIONS ARE THE PROPERTY OF ACCURATE INNOTECH INC AND SHALL NOT BE REPRODUCED, COPIED OR USED IN ANY MANNER WITHOUT THE PRIOR WRITTEN CONSENT OF ACCURATE INNOTECH INC.

雅安科技有限公司  
ACCURATE INNOTECH INC.

TITLE: SLIDE SWITCH / HORIZONTAL  
PART NO.: SK-12D12

DR: Ricky 2016/06/21  
DWG NO.: ADL-12D12

CHKD: Ricky 2016/06/21

APPD:

SCALE	SHEET	REV.	CUSTOMER DRAWING
4:1	1/1	A	