



RoHS Compliant  
2002/95/EC

REV.	ECN.	NO.	APPD.

MODEL CODE

SK-42D01- GEI

Knob Type	L(mm)
GEI	~
PGA	~

DIMENSIONS

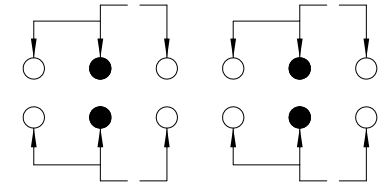
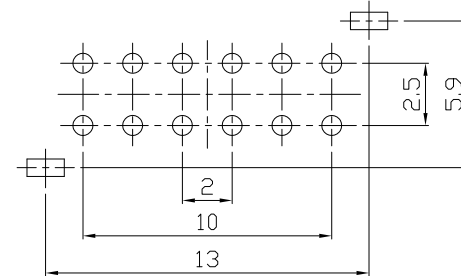
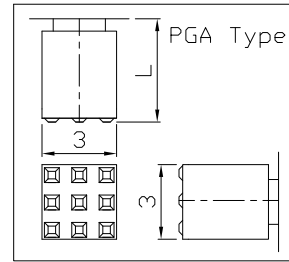
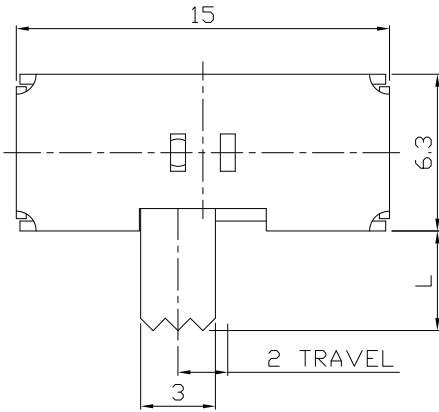

P.C.B LAYOUT  
BOTTOM VIEW

CIRCUIT DIAGRAM

ELECTRO-MECHANICAL CHARACTERISTICS  
Refer to additional specifications

RATING	0.3A 50V DC
CIRCUIT	4P2T
CONTACT RESISTANCE	100mΩ MAX.
TIMING	SHORTING
TRAVEL	2mm
OPERATING FORCE	300±100gf
OPERATING LIFE(cycles)	10,000

GEI Type

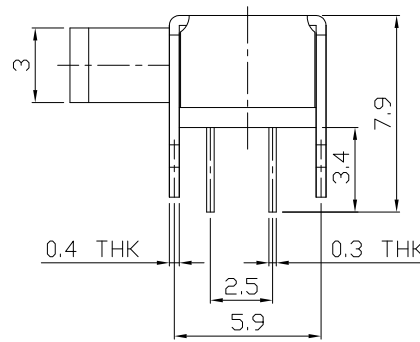
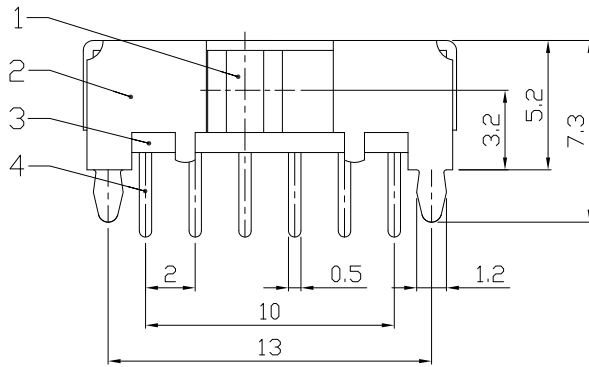

8					WITHIN 1.5mm: ±0.1mm	UNITS	mm
7					OVER 1.5mm: ±0.2mm	MAT'L	
6	SPRING PLATE	SUS	1	NATURAL		SEE NOTE	
5	CONTACT CLIP	PBS STRIP	4	Ag PLATED			
4	TERMINAL	BRASS STRIP	12	Ag PLATED			
3	BASE	PHENOLIC RESIN	1	NATURAL		FINISH	
2	FRAME	STEEL STRIP	1	Ni PLATED		SEE NOTE	
1	KNOB	POM	1	BLACK		Q'TY	
NO.	PARTS	MATERIAL	Q'TY	FINISHING			

THESE DRAWINGS AND SPECIFICATIONS ARE THE PROPERTY OF ACCURATE INNOTECH INC AND SHALL NOT BE REPRODUCED, COPIED OR USED IN ANY MANNER WITHOUT THE PRIOR WRITTEN CONSENT OF ACCURATE INNOTECH INC.

**雅安科技有限公司**  
**ACCURATE INNOTECH INC.**

TITLE:	SLIDE SWITCH / HORIZONTAL	PART NO.:	SK-42D01
DR:	Ricky 2016/07/19	DWG NO.:	ADL-42D01
CHKD:	Ricky 2016/07/19	SCALE	3:1
APPD:		SHEET	1/1
		REV.	A
		CUSTOMER DRAWING	