

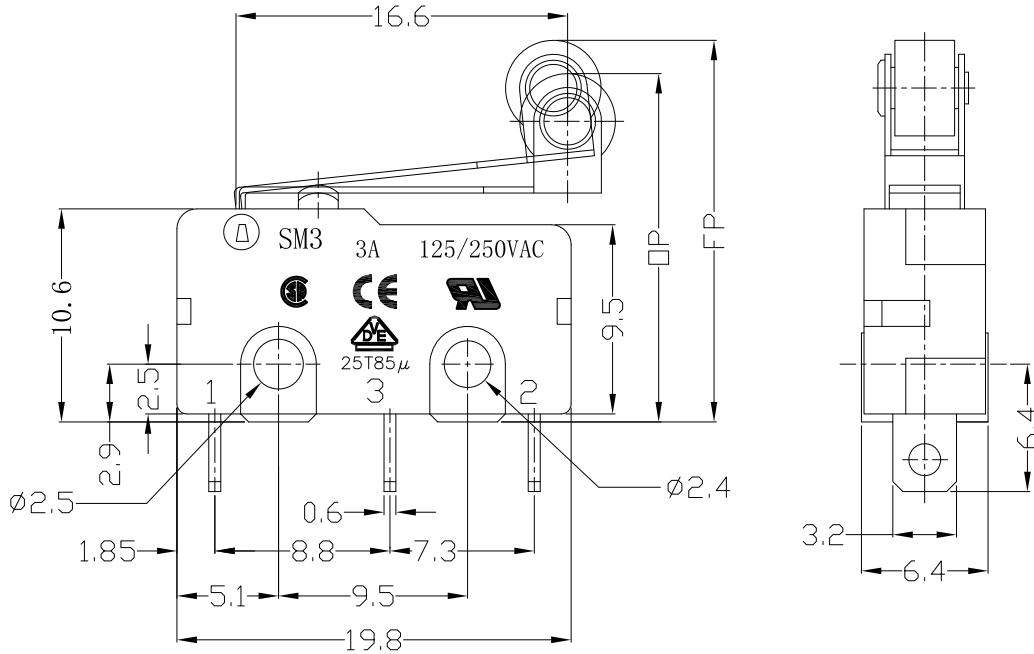

RoHS
Compliant
2002/95/EC

REV.	ECN.	NO.	APPD.

DIMENSIONS



MODEL CODE

SM 3-05 X-XX S-C31

1 2 3 4 5 6 7

- 1.Series : SM
- 2.Current Rating : 3=3A 125/250VAC
- 3.Actuator : 00=Non-lever 01-99=Lever
- 4.Termination : see chart (N/P/C/D)
(2=SPST-NO / 3=SPST-NC)
- 5.Operating Force : see chart
- 6.Spring Material:S=SUS304
- 7.Contact type: C31=3Amps Contact

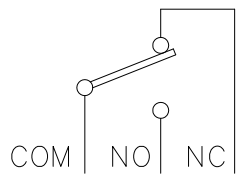

CIRCUIT DIAGRAM

1.Functional spec

1.1 Rated Voltage(AC)	125/250VAC
1.2 Rated Current(AC)	3A
1.3 Contact Resistance	≤100mΩ(Initial value)
1.4 Operating Force	30±12gf 45±20gf 68±25gf
1.5 Bounce Time	
1.6 Free Position	19.8±1.0mm
1.7 Operating Position	17.8±1.0mm
1.8 Position Travel	
1.9 Return Force	

2.Reliable Rating

2.1 Mechanical Life	1,000,000 CYCLES
2.2 Electrical Life	10,000 CYCLES
2.3 Insulation Resistance	≥100MΩ DC500V
2.4 Withstand Voltage	AC1000V 1 minute
2.5 Soldering Technic	Hand Soldering
2.6 Operating Temper	-25°C ~ +85°C
2.7 Ambient Humidity Used	<85%RH

Tolerance:±0.2	UNITS mm	雅安科技有限公司 ACCURATE INNOTECH INC.				
	MAT'L					
	SEE NOTE	TITLE:	PART NO.:			
	FINISH	MICRO SWITCH SM3 SERIES	SM3-05N-XXS-C31			
	SEE NOTE	DR: <i>Ricky</i> 2017/4/11	DWG NO.:			
	Q'TY	CHKD: <i>Ricky</i> 2017/4/11	ATD-05X-XXS-C31			
THESE DRAWINGS AND SPECIFICATIONS ARE THE PROPERTY OF ACCURATE INNOTECH INC AND SHALL NOT BE REPRODUCED, COPIED OR USED IN ANY MANNER WITHOUT THE PRIOR WRITTEN CONSENT OF ACCURATE INNOTECH INC.		APPD:	SCALE	SHEET	REV.	CUSTOMER DRAWING
			1:1	1/2	A	



RoHS
Compliant
2002/95/EC

REV.	ECN. NO.	NO.	APPD.

Terminal Type

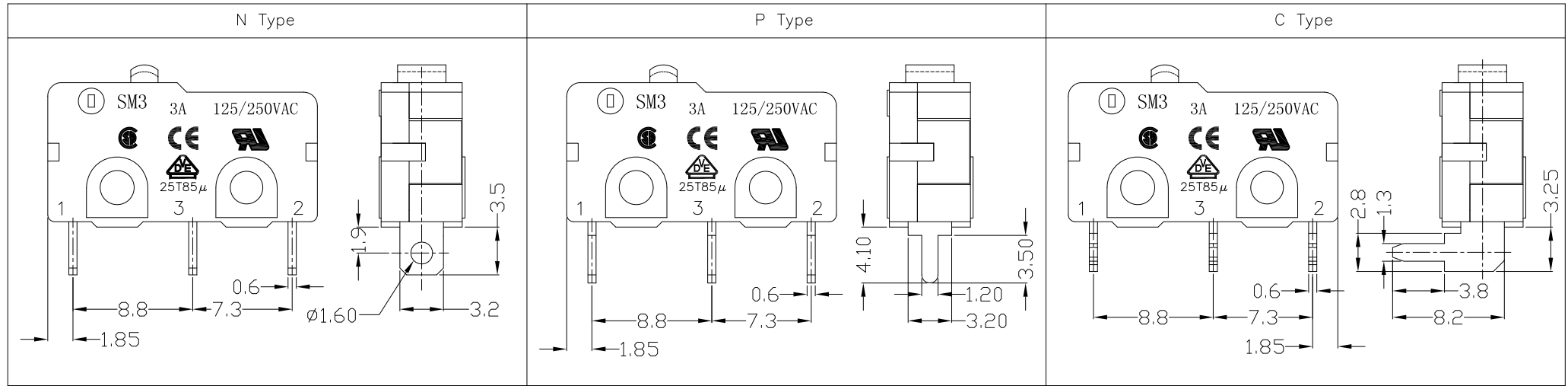

Structure chart

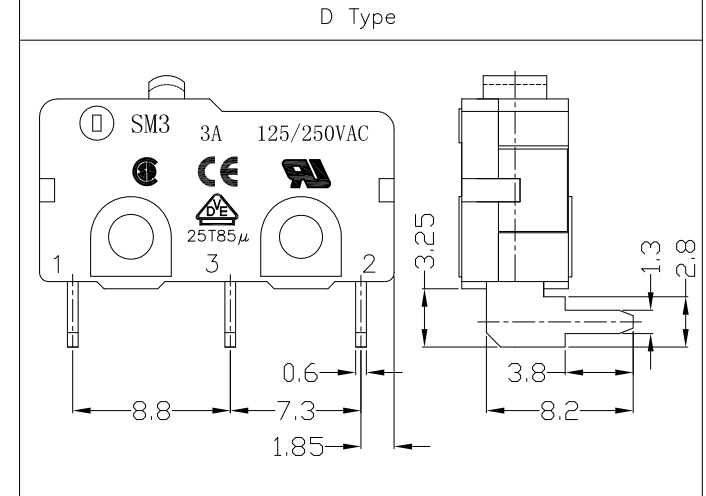
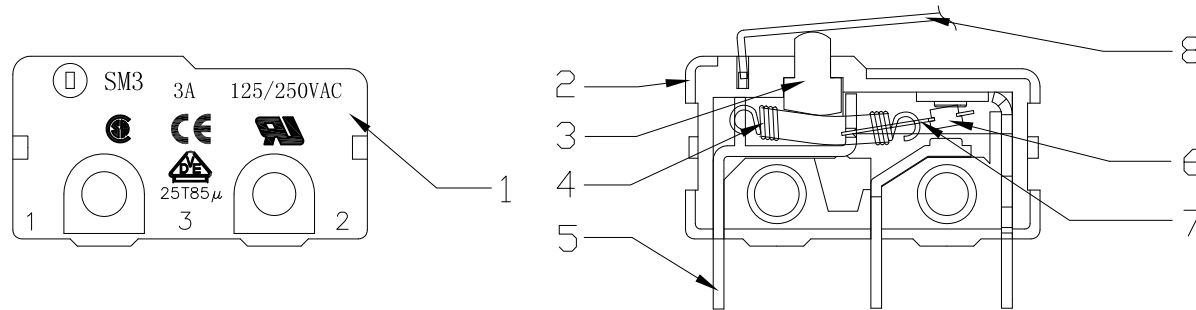

Material list

NO.	PARTS	MATERIAL	Q'TY	FINISHING
8	Lever	SUS301	1	
7	Change Plate	C5210	1	
6	Contact	Silver alloy	1	
5	Terminal	C2680	3	
4	Spring	SUS304	1	
3	Button	PBT	1	
2	Lower Housing	PBT	1	
1	Upper Housing	PBT	1	

Tolerance: ±0.2

UNITS mm

MAT'L SEE NOTE

FINISH SEE NOTE

Q'TY

THESE DRAWINGS AND SPECIFICATIONS ARE THE PROPERTY OF ACCURATE INNOTECH INC AND SHALL NOT BE REPRODUCED, COPIED OR USED IN ANY MANNER WITHOUT THE PRIOR WRITTEN CONSENT OF ACCURATE INNOTECH INC.

雅安科技有限公司 ACCURATE INNOTECH INC.			
TITLE: MICRO SWITCH SM3 SERIES		PART NO.: SM3-05X-XXS-C31	
DR: <i>Ricky</i> 2017/4/11		DWG NO.: ATD-05X-XXS-C31	
CHKD: <i>Ricky</i> 2017/4/11		SCALE 1:1	SHEET 2/2
APPD:		REV. A	CUSTOMER DRAWING



RoHS
Compliant
2002/95/EC

REV.	ECN.	NO.	APPD.

DIMENSIONS

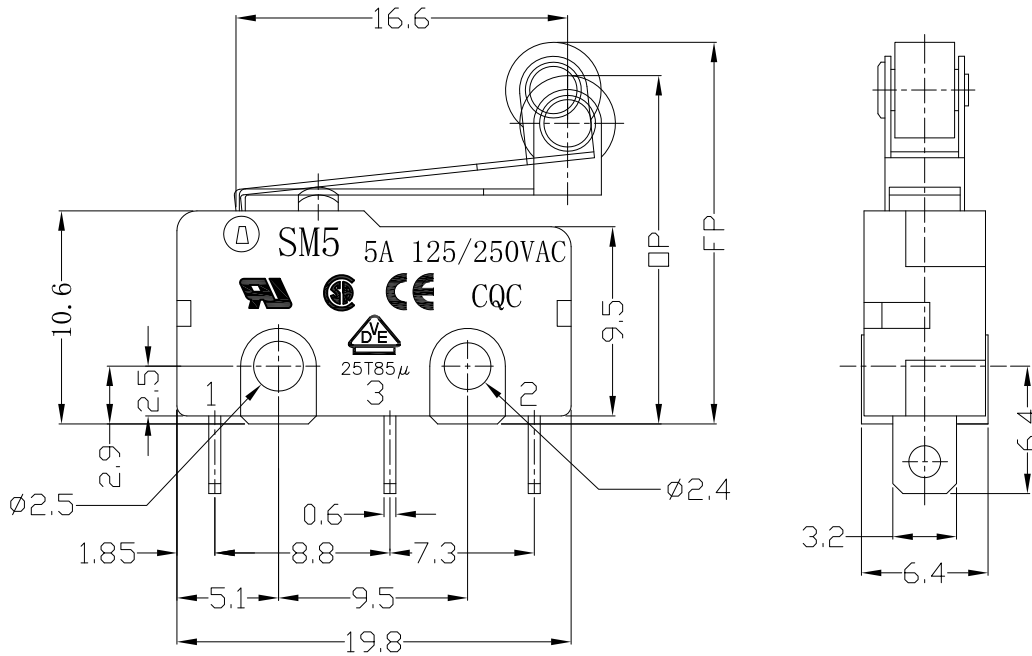

MODEL CODE

SM 5 - 05 X - XX S - C51

1 2 3 4 5 6 7

1. Series : SM
2. Current Rating : 5=5A 125/250VAC
3. Actuator : 00=Non-lever 01-99=Lever
4. Termination : see chart (N/P/C/D/L)
(2=SPST-NO / 3=SPST-NC)
5. Operating Force : see chart
6. Spring Material:S=SUS304
7. Contact type: C51=5Amps Contact

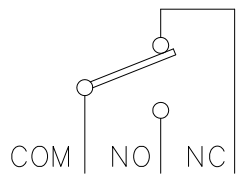

CIRCUIT DIAGRAM

1.Functional spec

1.1 Rated Voltage(AC)	125/250VAC
1.2 Rated Current(AC)	5A
1.3 Contact Resistance	≤100mΩ(Initial value)
1.4 Operating Force	30±12gf 45±20gf 68±25gf
1.5 Bounce Time	
1.6 Free Position	19.8±1.0mm
1.7 Operating Position	17.8±1.0mm
1.8 Position Travel	
1.9 Return Force	

2.Reliable Rating

2.1 Mechanical Life	1,000,000 CYCLES
2.2 Electrical Life	10,000 CYCLES
2.3 Insulation Resistance	≥100MΩ DC500V
2.4 Withstand Voltage	AC1000V 1 minute
2.5 Soldering Technic	Hand Soldering
2.6 Operating Temper	-25°C ~ +85°C
2.7 Ambient Humidity Used	<85%RH

Tolerance:±0.2	UNITS	雅安科技有限公司			
	mm	ACCURATE INNOTECH INC.			
	MAT'L	TITLE:	PART NO.:		
	SEE NOTE	MICRO SWITCH SM5 SERIES	SM5-05N-XXS-C51		
	FINISH	DR: <i>Ricky</i> 2017/4/12	DWG NO.:		
	SEE NOTE	CHKD: <i>Ricky</i> 2017/4/12	ATD-05X-XXS-C51		
THESE DRAWINGS AND SPECIFICATIONS ARE THE PROPERTY OF ACCURATE INNOTECH INC AND SHALL NOT BE REPRODUCED, COPIED OR USED IN ANY MANNER WITHOUT THE PRIOR WRITTEN CONSENT OF ACCURATE INNOTECH INC.	Q'TY	APPD:	SCALE	SHEET	REV.
			1:1	1/2	A
			CUSTOMER DRAWING		



RoHS
Compliant
2002/95/EC

REV.	ECN. NO.	NO.	APPD.

Terminal Type

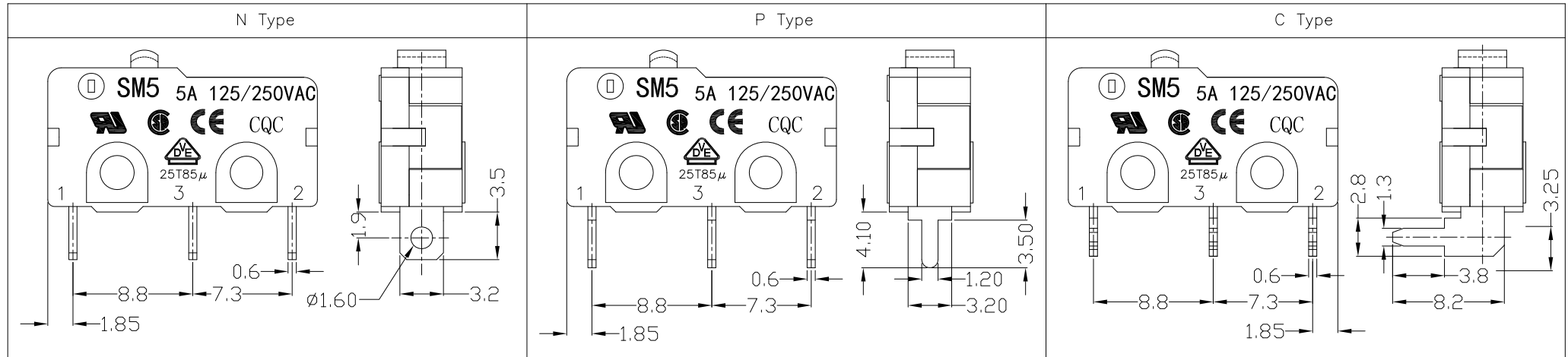

Structure chart

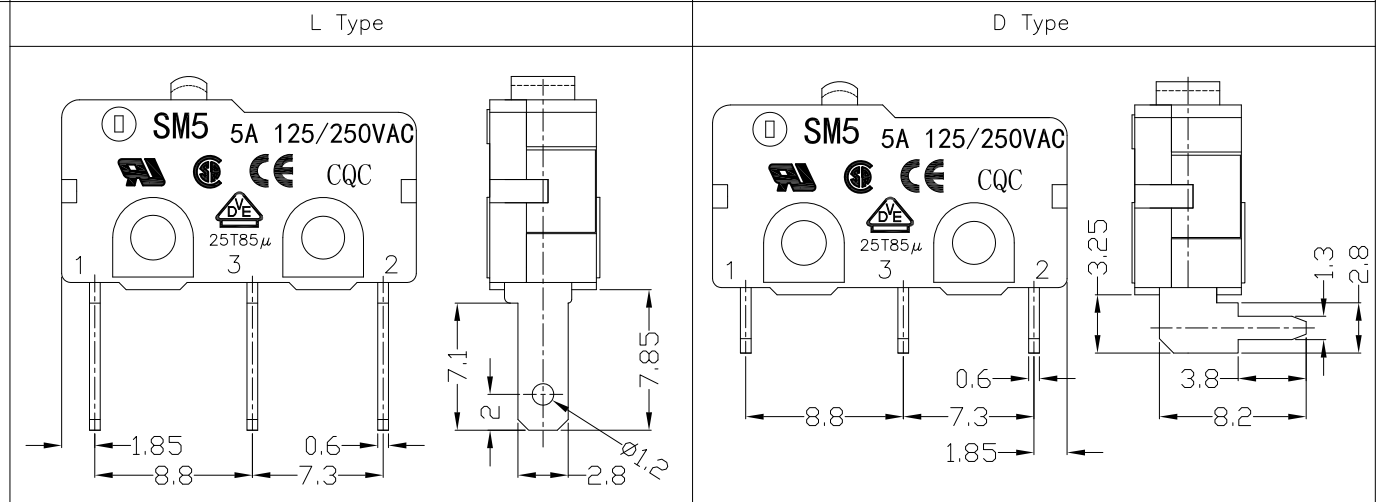
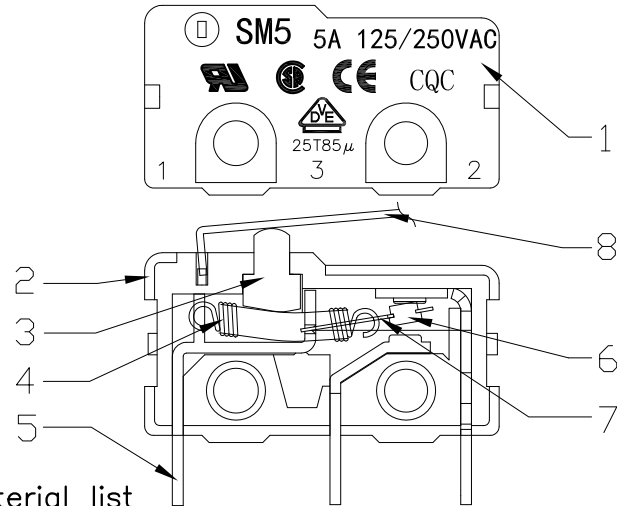

Material list

NO.	PARTS	MATERIAL	Q'TY	FINISHING
8	Lever	SUS301	1	
7	Change Plate	C5210	1	
6	Contact	Silver alloy	3	
5	Terminal	C2680	3	
4	Spring	SUS304	1	
3	Button	PBT	1	
2	Lower Housing	PBT	1	
1	Upper Housing	PBT	1	

Tolerance: ±0.2

UNITS mm

MAT'L

SEE NOTE

FINISH

SEE NOTE

Q'TY

THESE DRAWINGS AND SPECIFICATIONS ARE THE PROPERTY OF ACCURATE INNOTECH INC AND SHALL NOT BE REPRODUCED, COPIED OR USED IN ANY MANNER WITHOUT THE PRIOR WRITTEN CONSENT OF ACCURATE INNOTECH INC.

雅安科技有限公司 ACCURATE INNOTECH INC.			
TITLE: MICRO SWITCH SM5 SERIES		PART NO.: SM5-05X-XXS-C51	
DR: <i>Ricky</i> 2017/4/12		DWG NO.: ATD-05X-XXS-C51	
CHKD: <i>Ricky</i> 2017/4/12		SCALE	SHEET
APPD:		REV.	CUSTOMER
		1:1	2/2
		A	DRAWING