

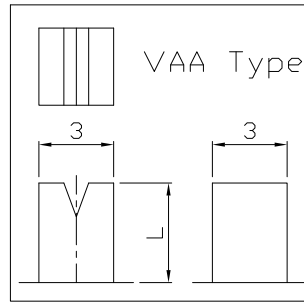

RoHS Compliant  
2002/95/EC

REV.	ECN. NO.	APPD.

DIMENSIONS

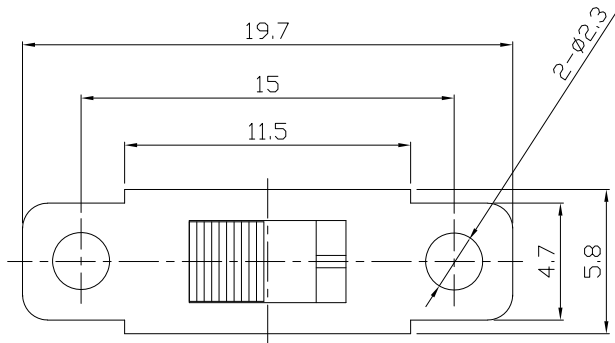

MODEL CODE

SS-12F31-GBG

Knob Type	L(mm)
GBG	~
VAA	~

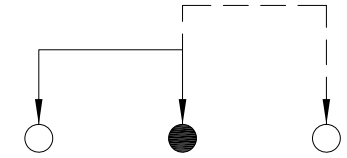
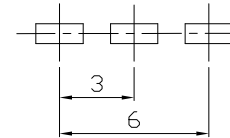

P.C.B LAYOUT  
BOTTOM VIEW

CIRCUIT DIAGRAM

ELECTRO-MECHANICAL CHARACTERISTICS  
Refer to additional specifications

RATING	0.5A 50V DC
CIRCUIT	1P2T
CONTACT RESISTANCE	100mΩ MAX.
TIMING	NON-SHORTING
TRAVEL	3mm
OPERATING FORCE	180±80gf
OPERATING LIFE(cycles)	10,000

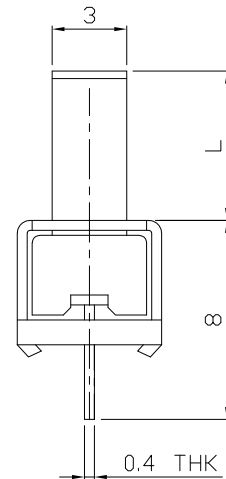
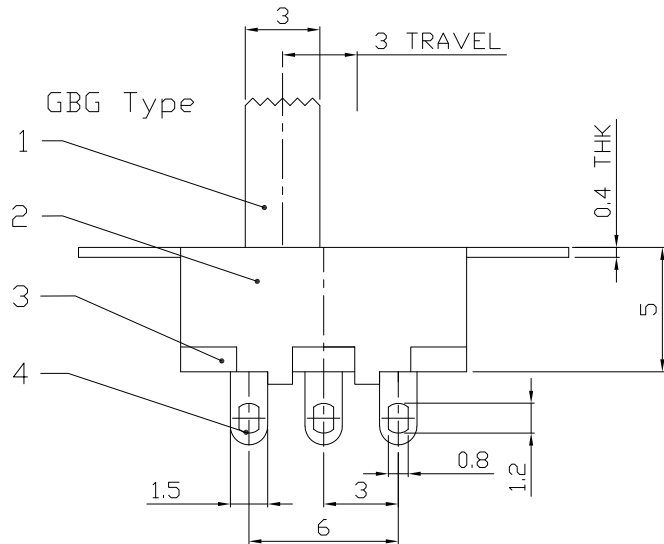

8					
7					
6	SPRING	STEEL WIRE	1	NATURAL	
5	CONTACT	BRASS STRIP	1	Ag PLATED	
4	TERMINAL	BRASS STRIP	3	Ag PLATED	
3	BASE	PHENOLIC RESIN	1	NATURAL	
2	FRAME	STEEL STRIP	1	Ni PLATED	
1	KNOB	POM	1	BLACK	
NO.	PARTS	MATERIAL	Q'TY	FINISHING	

WITHIN 1.5mm: ±0.1mm  
OVER 1.5mm: ±0.2mm

UNITS mm

MAT'L SEE NOTE

FINISH SEE NOTE

Q'TY

THESE DRAWINGS AND SPECIFICATIONS ARE THE PROPERTY OF ACCURATE INNOTECH INC AND SHALL NOT BE REPRODUCED, COPIED OR USED IN ANY MANNER WITHOUT THE PRIOR WRITTEN CONSENT OF ACCURATE INNOTECH INC.

雅安科技有限公司  
ACCURATE INNOTECH INC.

TITLE: SLIDE SWITCH / VERTICAL  
PART NO.: SS-12F31

DR: Ricky 2015/07/08  
DWG NO.: ADL-12F31

CHKD: Ricky 2015/07/08

APPD:

SCALE	SHEET	REV.	CUSTOMER DRAWING
3:1	1/1	A	