

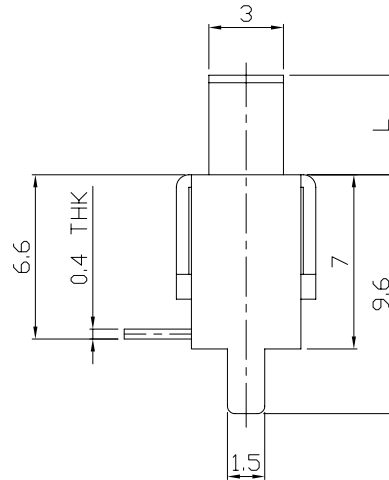

RoHS
Compliant
2002/95/EC

REV.	ECN.	NO.	APPD.

DIMENSIONS

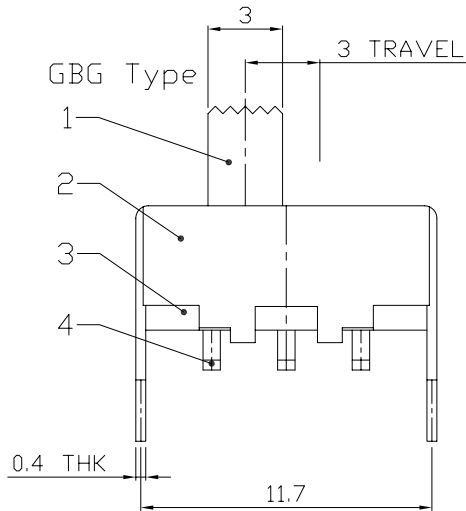
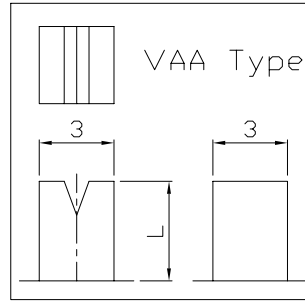
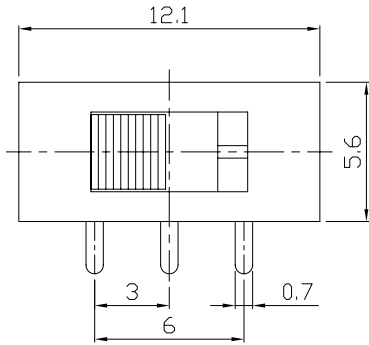

MODEL CODE

SS-12F37-GBG

Knob Type	L(mm)
GBG	~
VAA	~

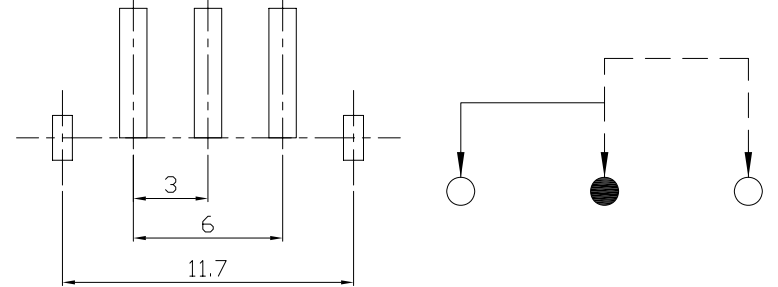

P.C.B LAYOUT
BOTTOM VIEW

CIRCUIT DIAGRAM

ELECTRO-MECHANICAL CHARACTERISTICS

Refer to additional specifications

RATING	0.5A 50V DC
CIRCUIT	1P2T
CONTACT RESISTANCE	100mΩ MAX.
TIMING	NON-SHORTING
TRAVEL	3mm
OPERATING FORCE	180±80gf
OPERATING LIFE(cycles)	10,000

8					
7					
6	SPRING	STEEL WIRE	1	NATURAL	
5	CONTACT	BRASS STRIP	1	Ag PLATED	
4	TERMINAL	BRASS STRIP	3	Ag PLATED	
3	BASE	PHENOLIC RESIN	1	NATURAL	
2	FRAME	STEEL STRIP	1	Ni PLATED	
1	KNOB	POM	1	BLACK	
NO.	PARTS	MATERIAL	Q'TY	FINISHING	

WITHIN 1.5mm: ±0.1mm
OVER 1.5mm: ±0.2mm

THESE DRAWINGS AND SPECIFICATIONS ARE THE PROPERTY OF ACCURATE INNOTECH INC AND SHALL NOT BE REPRODUCED, COPIED OR USED IN ANY MANNER WITHOUT THE PRIOR WRITTEN CONSENT OF ACCURATE INNOTECH INC.

UNITS	mm
MAT'L	SEE NOTE
FINISH	SEE NOTE
Q'TY	

雅安科技有限公司 ACCURATE INNOTECH INC.			
TITLE: SLIDE SWITCH / VERTICAL		PART NO.: SS-12F37	
DR: <i>Ricky</i> 2015/07/09		DWG NO.: ADL-12F37	
CHKD: <i>Ricky</i> 2015/07/09		SCALE	SHEET
APPD:		3:1	1/1
		REV.	CUSTOMER DRAWING
		A	