



RoHS
Compliant
2002/95/EC

MODEL CODE

SS-12F39-GBG

REV.	ECN.	NO.	APPD.

DIMENSIONS

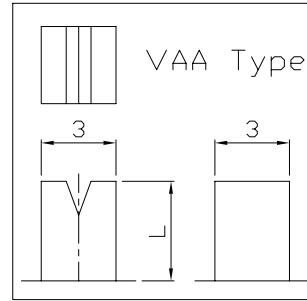
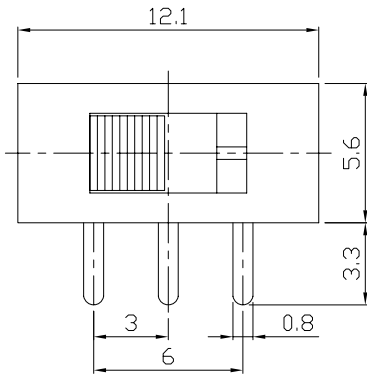

Knob Type	L(mm)
GBG	~
VAA	~

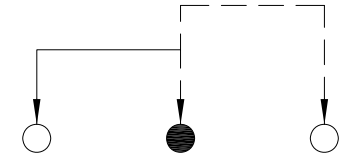
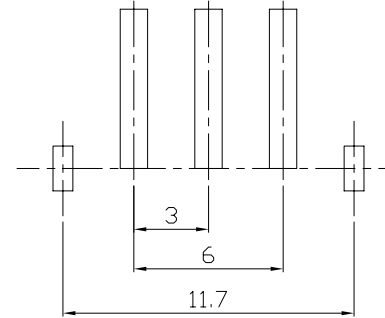

P.C.B LAYOUT
BOTTOM VIEW

CIRCUIT DIAGRAM

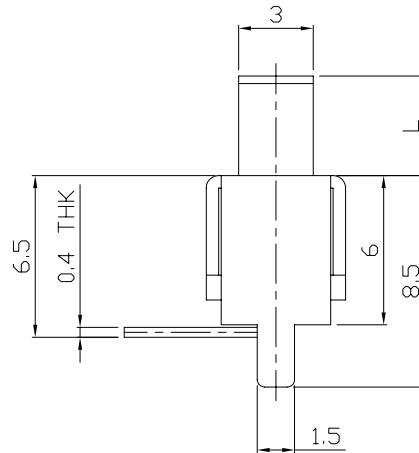
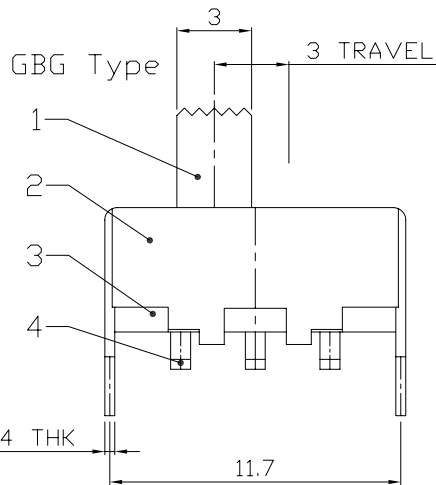

ELECTRO-MECHANICAL CHARACTERISTICS

Refer to additional specifications

RATING	0.5A 50V DC
CIRCUIT	1P2T
CONTACT RESISTANCE	100mΩ MAX.
TIMING	NON-SHORTING
TRAVEL	3mm
OPERATING FORCE	180±80gf
OPERATING LIFE(cycles)	10,000

NO.	PARTS	MATERIAL	Q'TY	FINISHING
8				
7				
6	SPRING	STEEL WIRE	1	NATURAL
5	CONTACT	BRASS STRIP	1	Ag PLATED
4	TERMINAL	BRASS STRIP	3	Ag PLATED
3	BASE	PHENOLIC RESIN	1	NATURAL
2	FRAME	STEEL STRIP	1	Ni PLATED
1	KNOB	POM	1	BLACK

WITHIN 1.5mm: ±0.1mm
OVER 1.5mm: ±0.2mm

UNITS mm

MAT'L SEE NOTE

FINISH SEE NOTE

Q'TY

THESE DRAWINGS AND SPECIFICATIONS ARE THE PROPERTY OF ACCURATE INNOTECH INC AND SHALL NOT BE REPRODUCED, COPIED OR USED IN ANY MANNER WITHOUT THE PRIOR WRITTEN CONSENT OF ACCURATE INNOTECH INC.

雅安科技有限公司 ACCURATE INNOTECH INC.			
TITLE: SLIDE SWITCH / VERTICAL	PART NO.: SS-12F39		
DR: <i>Ricky</i> 2015/07/09	DWG NO.: ADL-12F39		
CHKD: <i>Ricky</i> 2015/07/09	SCALE 3:1	SHEET 1/1	REV. A
APPD:	CUSTOMER DRAWING		