



RoHS Compliant
2002/95/EC

| REV. | ECN. NO. | APPD. |
|------|----------|-------|
| | | |
| | | |

MODEL CODE

SS-22H02-GBF

| |
|-----------|
| Knob Type |
| GBF |
| VAI |

| |
|-------|
| L(mm) |
| ~ |

DIMENSIONS

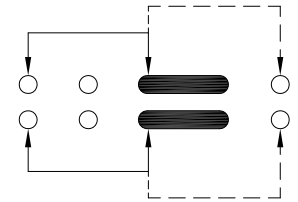
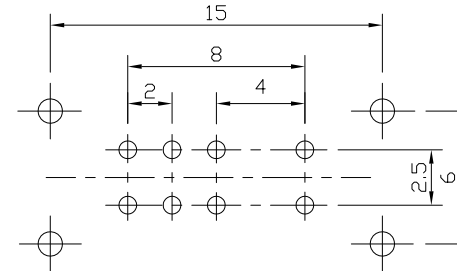
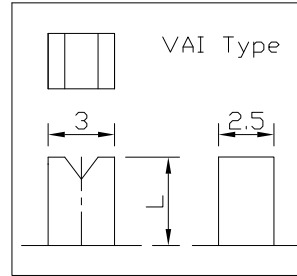
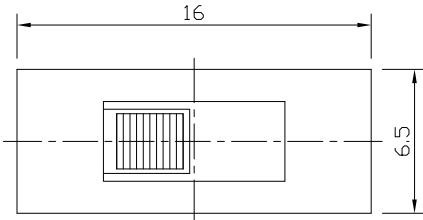

P.C.B LAYOUT
BOTTOM VIEW

CIRCUIT DIAGRAM

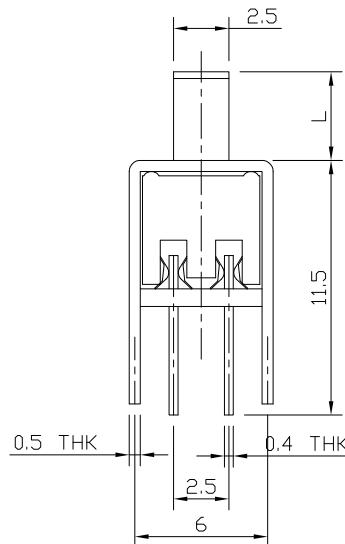
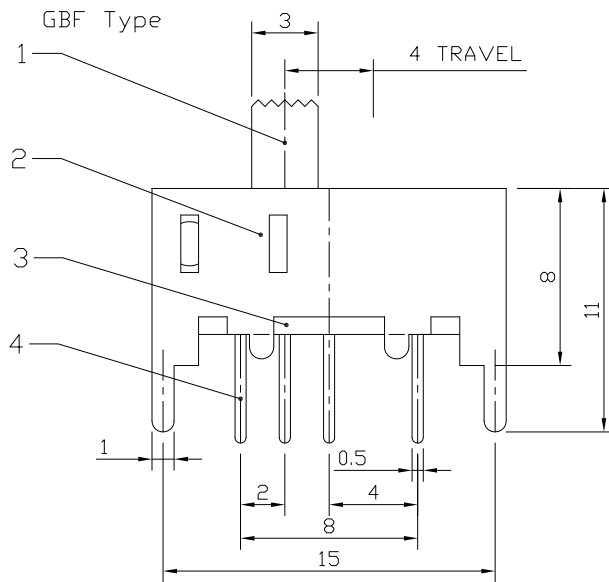

ELECTRO-MECHANICAL CHARACTERISTICS
Refer to additional specifications

| | |
|------------------------|-------------|
| RATING | 0.3A 50V DC |
| CIRCUIT | 2P2T |
| CONTACT RESISTANCE | 100mΩ MAX. |
| TIMING | NO SHORTING |
| TRAVEL | 4mm |
| OPERATING FORCE | 250±100gf |
| OPERATING LIFE(cycles) | 10,000 |

| NO. | PARTS | MATERIAL | Q'TY | FINISHING |
|-----|--------------|----------------|------|-----------|
| 8 | | | | |
| 7 | STEEL BALL | STEEL | 1 | NATURAL |
| 6 | SPRING | STEEL WIRE | 1 | NATURAL |
| 5 | CONTACT CLIP | PBS STRIP | 2 | Ag PLATED |
| 4 | TERMINAL | BRASS STRIP | 8 | Ag PLATED |
| 3 | BASE | PHENOLIC RESIN | 1 | NATURAL |
| 2 | FRAME | STEEL STRIP | 1 | Ni PLATED |
| 1 | KNOB | POM | 1 | BLACK |

WITHIN 1.5mm: ±0.1mm
OVER 1.5mm: ±0.2mm

UNITS mm

MAT'L SEE NOTE

FINISH SEE NOTE

Q'TY

THESE DRAWINGS AND SPECIFICATIONS ARE THE PROPERTY OF ACCURATE INNOTECH INC AND SHALL NOT BE REPRODUCED, COPIED OR USED IN ANY MANNER WITHOUT THE PRIOR WRITTEN CONSENT OF ACCURATE INNOTECH INC.

雅安科技有限公司
ACCURATE INNOTECH INC.

TITLE: SLIDE SWITCH / VERTICAL
PART NO.: SS-22H02

DR: Ricky 2015/05/27
DWG NO.: ADL-22H02

CHKD: Ricky 2015/05/27

APPD:

| | | | |
|-------|-------|------|------------------|
| SCALE | SHEET | REV. | CUSTOMER DRAWING |
| 3:1 | 1/1 | A | |