



RoHS Compliant
2002/95/EC



REV.	ECN.	NO.	APPD.

DIMENSIONS

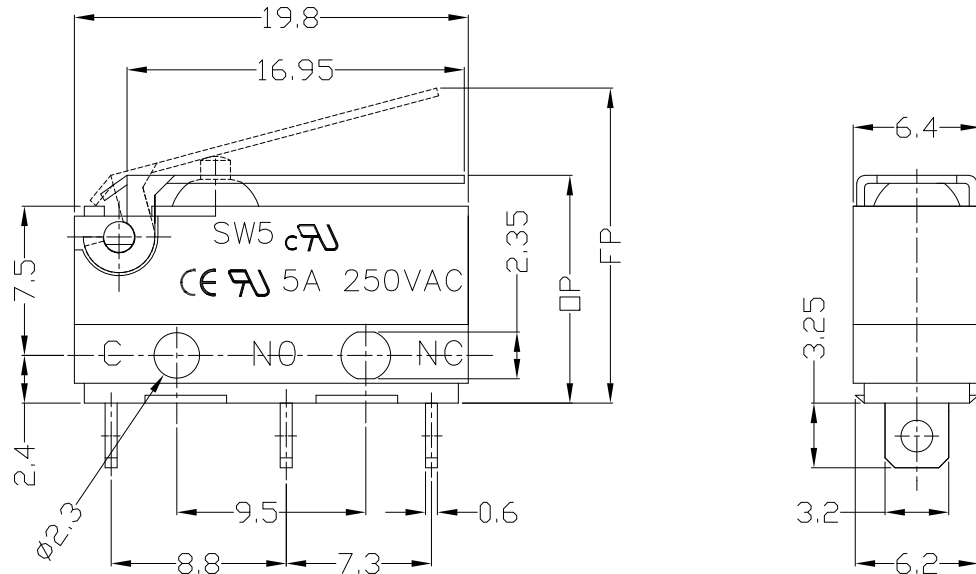

MODEL CODE

SW5-01X-XX-C5-M

1 2 3 4 5 6 7

- 1.Series : SW
- 2.Current Rating: 5=5A 250VAC
- 3.Actuator: 00=Non-lever 01-99=Lever
- 4.Termination: N (2=SPST-NO)
- 5.Operating Force: see chart
- 6.Contact type: C5=5Amps Contact
- 7.Body type: M=6.4mm(the teminal can be solder waterproof wires)

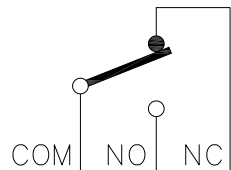

CIRCUIT DIAGRAM

1.Functional spec

1.1 Rated Voltage	250VAC		
1.2 Rated Current	5A		
1.3 Contact Resistance	≤100mΩ(Initial value)		
1.4 Operating Force	45±20gf	60±25gf	100±40gf
1.5 Free Position	15.5±1.0mm		
1.6 Operating Position	13.5±1.0mm		

2.Reliable Rating

2.1 Mechanical Life	1,000,000 CYCLES		
2.2 Electrical Life	10,000 CYCLES		
2.3 Insulation Resistance	≥100MΩ DC500V		
2.4 Withstand Voltage	AC1000V 1 minute		
2.5 Soldering Technic	Hand Soldering		
2.6 Operating Temper	-25°C ~ +80°C		
2.7 Ambient Humidity Used	<85%RH		

Tolerance:±0.2	UNITS	雅安科技有限公司 ACCURATE INNOTECH INC.			
	mm				
	MAT'L	TITLE:		PART NO.:	
	SEE NOTE	MICRO SWITCH Waterproof SW5 SERIES		SW5-01N-XX-C5-M	
	FINISH	DR: <i>Ricky</i> 2017/3/9		DWG NO.:	
	SEE NOTE	CHKD: <i>Ricky</i> 2017/3/9		ATD-01N-XX-C5-M	
THESE DRAWINGS AND SPECIFICATIONS ARE THE PROPERTY OF ACCURATE INNOTECH INC AND SHALL NOT BE REPRODUCED, COPIED OR USED IN ANY MANNER WITHOUT THE PRIOR WRITTEN CONSENT OF ACCURATE INNOTECH INC.	Q'TY	APPD:		SCALE	SHEET
				1:1	1/2
		REV.	CUSTOMER DRAWING		
		A			



RoHS
Compliant
2002/95/EC



REV.	ECN.	NO.	APPD.

Structure chart

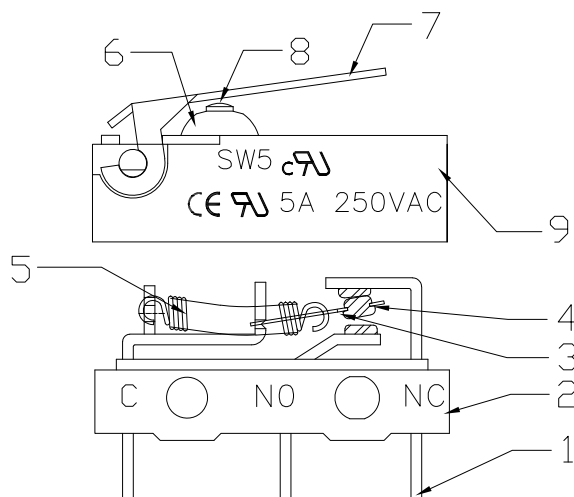

3. Protection class	Test conditions and technical requirement	Conclusion to determine
3.1 protection against ingress of dust $\le 0.10\text{mm}$ (IP5X)	The switches are placed in a position of normal use inside the test chamber. The test is carried out according to the second enclosure of IEC60529-1989. The test shall be continued for a period of 8h. After testing, the switches are taken out of the chamber and left at $25\pm 10^\circ\text{C}$ conditions. Load Rating: 5A 250VAC, test the temperature rise of the switches.	After test: 1. Operating is normal; 2. The temperature rise shall not exceed 50K; 3. Between terminals, terminal and surface of the crust, dielectric withstand in voltage $\ge 1000\text{V}$
3.2 protection against ingress of water (IPX1)	The switches are placed in an oven which the temperature is $70\pm 2^\circ\text{C}$ for 240 hours. Then the switches are taken out of the oven immediately and left at $25\pm 10^\circ\text{C}$ conditions for 16 hours. After that, testing protection against ingress of water. During the testing, the temperature between the water and the samples shall not exceed 5K, and the switches have no electric current.	After test: 1. The body of the switch and the airproof cap have no transmutation, dilatation, induration; 2. The switch shall withstand the dielectric strength $\ge 1000\text{V}$ 3. There is no trace of water on insulation which could result in a reduction of creepage distances and clearances below the values specified.
3.3 reference standards and conditions	IEC60529-1989 IEC61058-1:1996 Environment condition: temperature range $15^\circ\text{C}-35^\circ\text{C}$	

Material list

NO.	PARTS	MATERIAL	Q'TY	FINISHING	Tolerance: ± 0.2	UNITS mm	雅安科技有限公司 ACCURATE INNOTECH INC.					
9	Upper Housing	Nylon	1	Black		MAT'L	TITLE:		PART NO.:			
8	Button	PBT	1	Black			SEE NOTE	MICRO SWITCH Waterproof SW5 SERIES		SW5-01N-XX-C5-M		
7	Lever	SUS301	1			FINISH	DR: <i>Ricky</i> 2017/3/9		DWG NO.:			
6	Cap	RUBBER	1				SEE NOTE	CHKD: <i>Ricky</i> 2017/3/9		ATD-01N-XX-C5-M		
5	Spring	SUS304	1			Q'TY	APPD:		SCALE	SHEET	REV.	CUSTOMER
4	Contact	Silver alloy	3				SEE NOTE	1:1		2/2	A	DRAWING
3	Change Plate	C5210	1			Q'TY	APPD:					
2	Base	Nylon	1	Black			SEE NOTE	1:1				
1	Terminal	C2680	3		THESE DRAWINGS AND SPECIFICATIONS ARE THE PROPERTY OF ACCURATE INNOTECH INC AND SHALL NOT BE REPRODUCED, COPIED OR USED IN ANY MANNER WITHOUT THE PRIOR WRITTEN CONSENT OF ACCURATE INNOTECH INC.							