

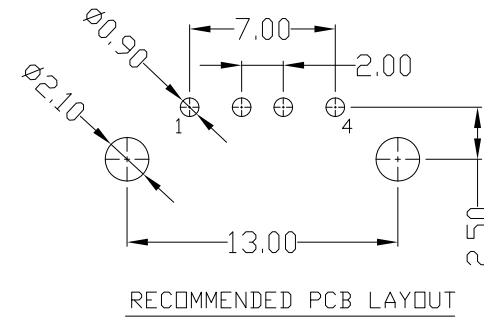

RoHS
Compliant
2002/95/EC

REV	LTR	DESCRIPTION	DATE	REVISER	APPD

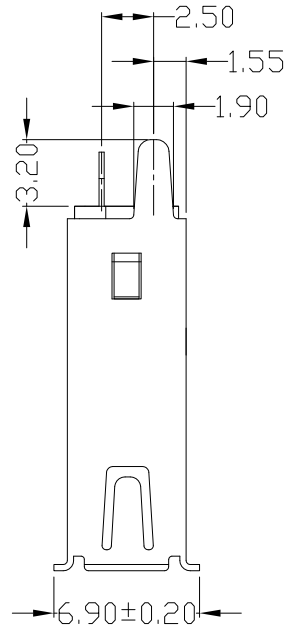
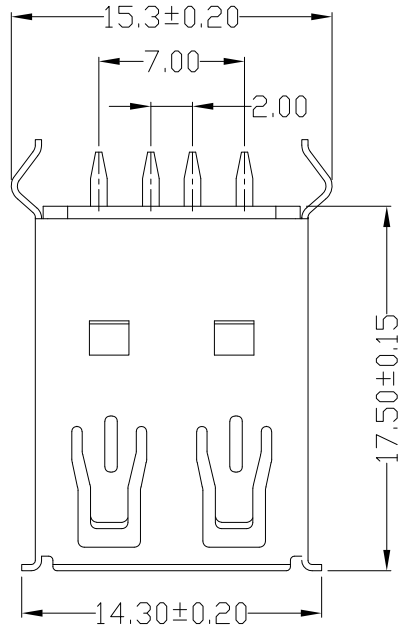
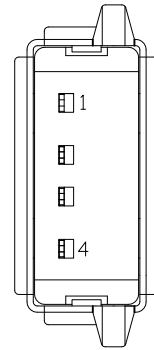

NOTES:

- ELECTRICAL:
 - VOLTAGE CURRENT RATING: 2AMP,30V AC;
 - INSULATION RESISTANCE: 1000MΩ MIN;
 - CONTACT RESISTANCE: 30mΩ MAX;
 - WITHSTANDING VOLTAGE: 500V AC;
 - OPERATING TEMPERATURE: -55°C TO +85°C.
- Mechanical:
 - Mating Force: 35N MAX
 - Unmating Force: 10N MIN.
- NOTE:1.DIMENSIONS MARKED "▼"
TO BE CHECKED BY Q.C & IPQC.

4.PART NO.

USAF-041N-1*PZ20-S

1Au 1U"
6Au 30U"
W/WHITE
B/BLACK
1PBT
2PA6T
3PA9T
4LCP

Bill of materials:

NO	PARTS	MATERIAL	QTY	FINISHING	UNITS	mm	雅安科技有限公司 ACCURATE INNOTECH INC.			
3	HOUSING	PBT+30%GF	1		X. ±0.35	X.' ±2'	TITLE: USB AF DIP 180度 全包 卷边弯脚有后塞 17.5 PART NO.: USAF-04XN-1XPZ20-S DR: Ricky 2018/11/21 DWG NO.: AII-PZ20-S CHKD: Ricky 2018/11/21 SCALE: 1:1 SHEET: 1/1 REV: B CUSTOMER DRAWING			
2	SHELL	SPCC	1	PLATED NICKEL	.X ±0.3	.X' ±1'				
1	TERMINAL	COPPER ALLOY	4	PLATED GOLD/TIN	.XX ±0.25	.XX'				
					.XXX ±0.15	.XXX'				
					<small>THESE DRAWINGS AND SPECIFICATIONS ARE THE PROPERTY OF ACCURATE INNOTECH INC AND SHALL NOT BE REPRODUCED, COPIED OR USED IN ANY MANNER WITHOUT THE PRIOR WRITTEN CONSENT OF ACCURATE INNOTECH INC.</small>		APPD:			