

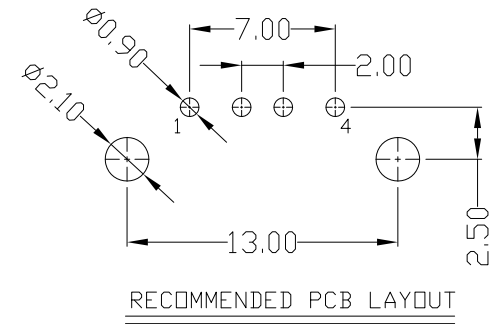

RoHS  
Compliant  
2002/95/EC

REV	LTR	DESCRIPTION	DATE	REVISER	APPD

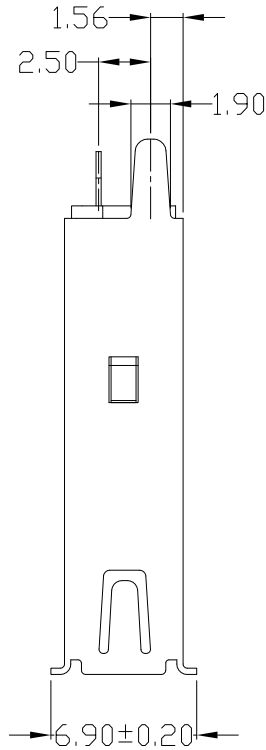
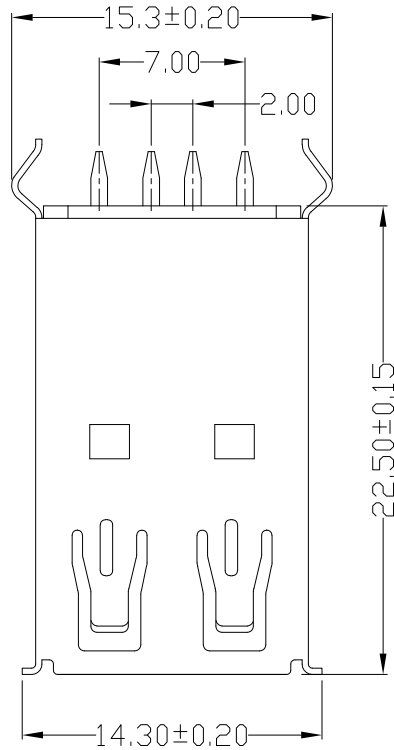
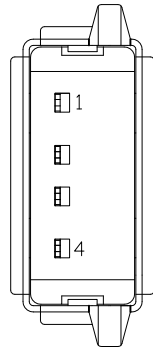

NOTES:

- ELECTRICAL:
  - VOLTAGE CURRENT RATING: 2AMP,30V AC;
  - INSULATION RESISTANCE: 1000MΩ MIN;
  - CONTACT RESISTANCE: 30mΩ MAX;
  - WITHSTANDING VOLTAGE: 500V AC;
  - OPERATING TEMPERATURE: -55°C TO +85°C.
- Mechanical:
  - Mating Force: 35N MAX
  - Unmating Force: 10N MIN.
- NOTE:1.DIMENSIONS MARKED "▼"  
TO BE CHECKED BY Q.C & IPQC.

4.PART NO.

USAF-041N-1\*PZ214-S

1Au 1U"  
6Au 30U"

W/WHITE  
B/BLACK  
1PBT  
2PA6T  
3PA9T  
4LCP

Bill of materials:

NO	PARTS	MATERIAL	QTY	FINISHING	X. ±0.35	X.' ±2'	UNITS	雅安科技有限公司 ACCURATE INNOTECH INC.					
							mm						
3	HOUSING	PBT+30%GF	1		.X ±0.3	.X' ±1'	MAT'L	TITLE:	PART NO.:				
2	SHELL	SPCC	1	PLATED NICKEL	.XX ±0.25	.XX'	SEE NOTE	DR:	USAF-041N-1*PZ214-S				
1	TERMINAL	COPPER ALLOY	4	PLATED GOLD/TIN	.XXX ±0.15	.XXX'	FINISH	CHKD:	USAF-04XN-1XPZ214-S				
					THESE DRAWINGS AND SPECIFICATIONS ARE THE PROPERTY OF ACCURATE INNOTECH INC AND SHALL NOT BE REPRODUCED, COPIED OR USED IN ANY MANNER WITHOUT THE PRIOR WRITTEN CONSENT OF ACCURATE INNOTECH INC.		SEE NOTE	DWG NO.:	AII-PZ214-S				
							Q'TY	APPD:	SCALE	SHEET	REV.	CUSTOMER DRAWING	
									1:1	1/1	B		