

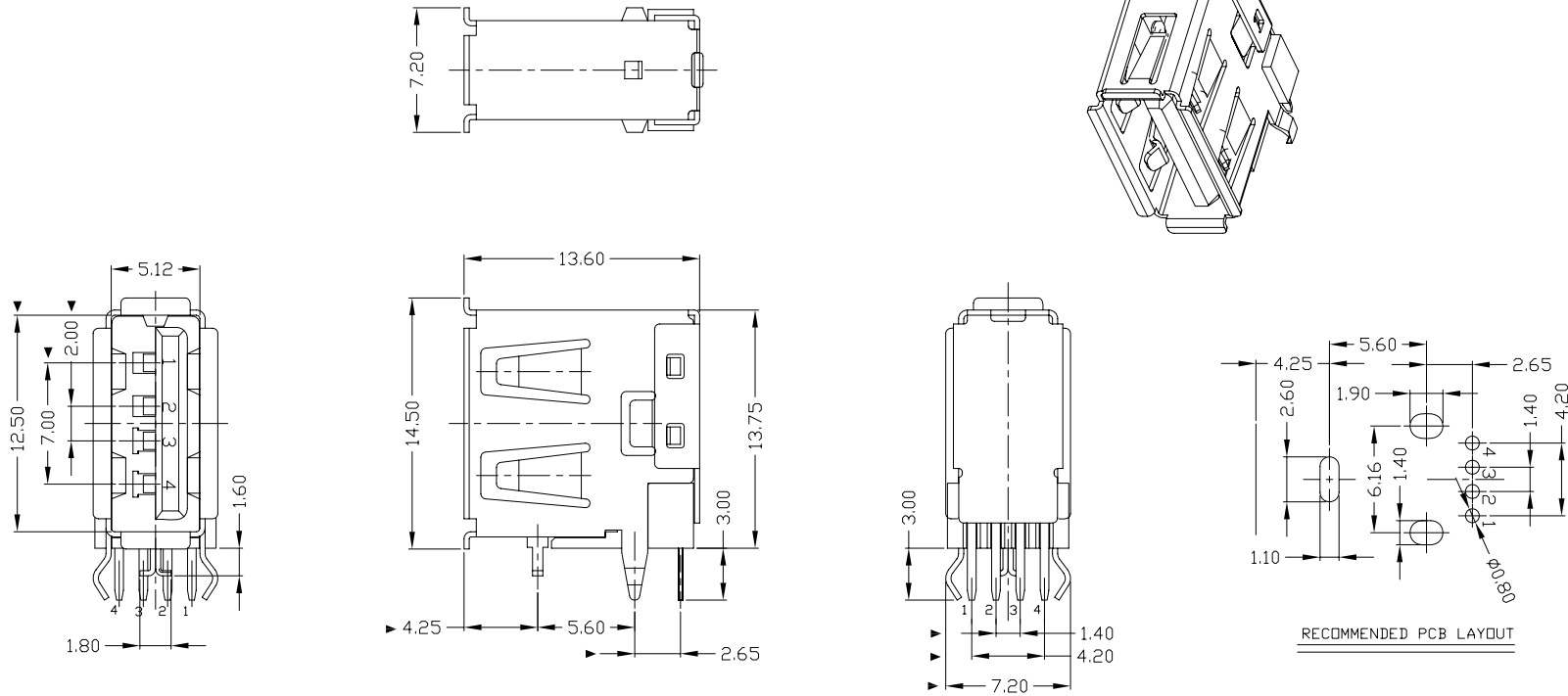

RoHS  
Compliant  
2002/95/EC

REV.	ECN.	NO.	APPD.



NOTES:

- ELECTRICAL:
  - VOLTAGE CURRENT RATING: 2AMP, 30V AC;
  - INSULATION RESISTANCE: 1000M $\Omega$ MIN;
  - CONTACT RESISTANCE: 30m $\Omega$ MAX;
  - WITHSTANDING VOLTAGE: 750V AC;
  - OPERATING TEMPERATURE: -55°C TO +85°C.
- Mechanical:
  - Mating Force: 35N MAX
  - Unmating Force: 10N MIN.
- NOTE: 1. DIMENSIONS MARKED "▼" TO BE CHECKED BY Q.C & IPQC.

4. PART NO.

USAF-04\*N-1\*C35

1: Au 1U"  
6: Au 30U"

W: WHITE  
B: BLACK

1: PBT  
2: PA6T  
3: PA9T  
4: LCP

Bill of materials:

NO	PARTS	MATERIAL	QTY	FINISHING	UNITS	mm	雅安科技有限公司 ACCURATE INNOTECH INC.				
3	HOUSING	PBT+30%GF	1	UL94V-0	X. $\pm 0.35$	X.* $\pm 2'$	TITLE:	PART NO.:			
2	SHELL	COPPER ALLOY	1	PLATED NICKEL	.X $\pm 0.3$	.X* $\pm 1'$	DR:	USAF-04*N-1*C35			
1	TERMINAL	COPPER ALLOY	4	PLATED GOLD/TIN	.XX $\pm 0.25$	.XX*	CHKD:	DWG NO.:			
					.XXX $\pm 0.15$	.XXX*	APPD:	AII-C35			
					THESE DRAWINGS AND SPECIFICATIONS ARE THE PROPERTY OF ACCURATE INNOTECH INC AND SHALL NOT BE REPRODUCED, COPIED OR USED IN ANY MANNER WITHOUT THE PRIOR WRITTEN CONSENT OF ACCURATE INNOTECH INC.		SCALE	SHEET	REV.	CUSTOMER DRAWING	