

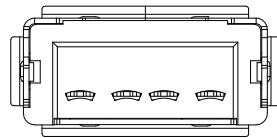

RoHS
Compliant
2002/95/EC

REV.	ECN.	NO.	APPD.

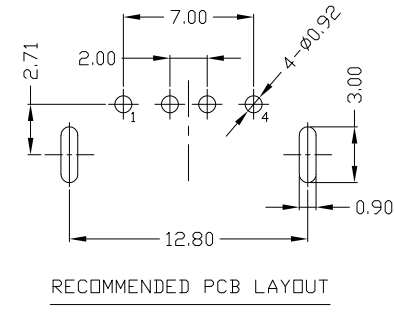
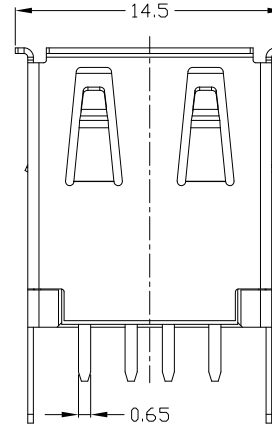
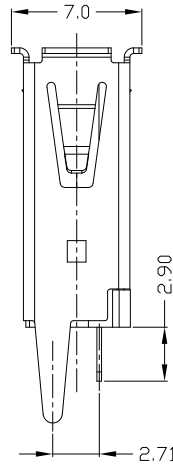
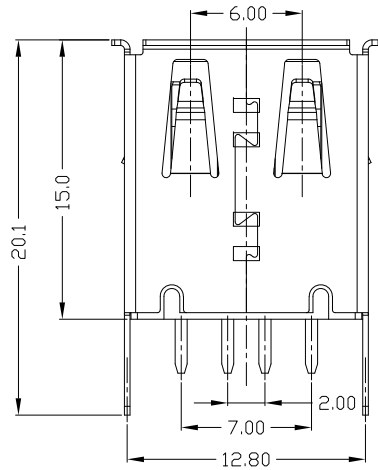
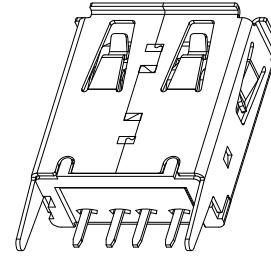
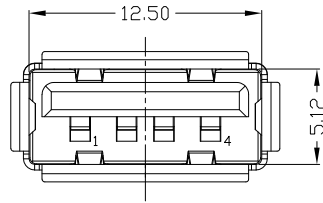

NOTES:

- ELECTRICAL:
 - VOLTAGE CURRENT RATING: 2AMP, 30V AC;
 - INSULATION RESISTANCE: 1000MΩMIN;
 - CONTACT RESISTANCE: 30mΩMAX;
 - WITHSTANDING VOLTAGE: 500V AC;
 - OPERATING TEMPERATURE: -55°C TO +85°C.
- Mechanical:
 - Mating Force: 35N MAX
 - Unmating Force: 10N MIN.
- DIMENSIONS MARKED "▼" TO BE CHECKED BY Q.C & IPQC.

4. PART NO.

USAF-04*N-1*P602

- 1: Au 1U*
- 6: Au 30U*
- W: WHITE
- B: BLACK
- 1: PBT
- 2: PA6T
- 3: PA9T
- 4: LCP

Bill of materials:

E	4	COVER	PBT+30%GF	1	UL94V-0	X. ±0.35	X.' ±2'	UNITS	mm	雅安科技有限公司 ACCURATE INNOTECH INC.
	3	HOUSING	PBT+30%GF	1	UL94V-0	.X ±0.3	.X' ±1'	MAT'L	SEE NOTE	
	2	SHELL	COPPER ALLOY/SPCC	1	PLATED NICKEL	.XX ±0.25	.XX'	FINISH	SEE NOTE	
	1	TERMINAL	COPPER ALLOY	4	PLATED GOLD/TIN	.XXX ±0.15	.XXX'	Q'TY	SEE NOTE	
	NO	PARTS	MATERIAL	QTY	FINISHING	<small>THESE DRAWINGS AND SPECIFICATIONS ARE THE PROPERTY OF ACCURATE INNOTECH INC AND SHALL NOT BE REPRODUCED, COPIED OR USED IN ANY MANNER WITHOUT THE PRIOR WRITTEN CONSENT OF ACCURATE INNOTECH INC.</small>			TITLE: USB AF DIP 180° 全直脚 卷边 (15.0)	PART NO.: USAF-04*N-1*P602
								DR: gan 2016/9/20 CHKD: gan 2016/9/20 APPD:	DWG NO.: AII-P602	SCALE: 1:1 SHEET: 1/1 REV: B CUSTOMER DRAWING