

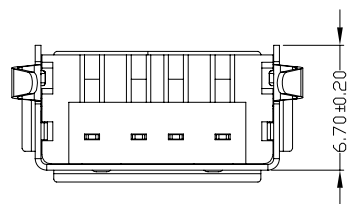

RoHS
Compliant
2002/95/EC

REV.	ECN.	NO.	APPD.

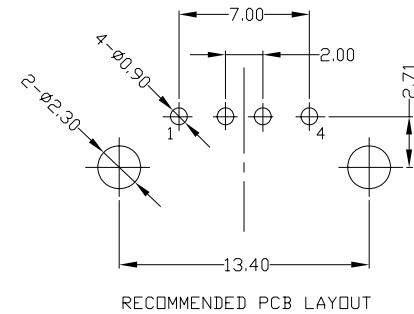
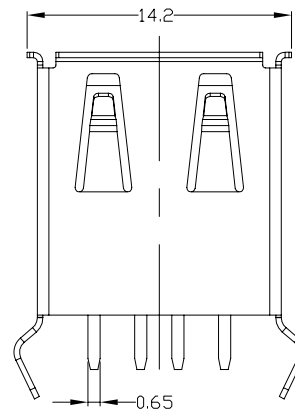
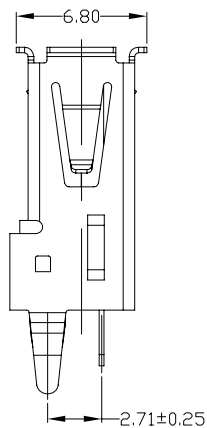
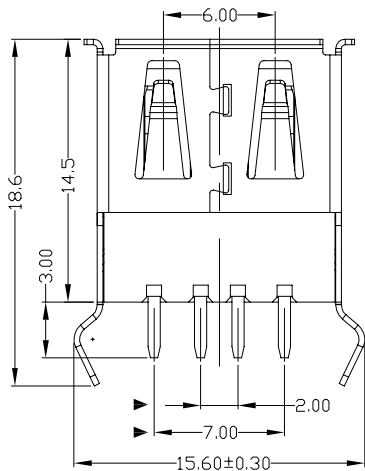
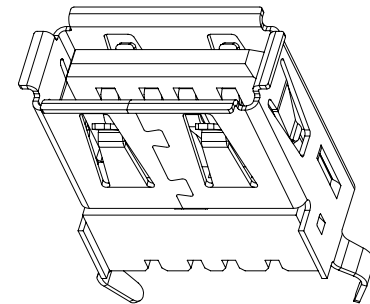
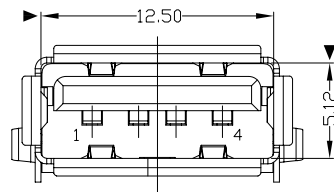

NOTES:

- ELECTRICAL:
 - VOLTAGE CURRENT RATING: 2AMP, 30V AC;
 - INSULATION RESISTANCE: 1000MΩ MIN;
 - CONTACT RESISTANCE: 30mΩ MAX;
 - WITHSTANDING VOLTAGE: 500V AC;
 - OPERATING TEMPERATURE: -55°C TO +85°C.
- Mechanical:
 - Mating Force: 35N MAX
 - Unmating Force: 10N MIN.
- NOTE: 1. DIMENSIONS MARKED "▼" TO BE CHECKED BY Q.C & IPQC.

4. PART NO.

USAF-04*N-1*P63

1Au 1U*
6Au 30U*

W: WHITE
B: BLACK

1PBT
2PA6T
3PA9T
4LCP

Bill of materials:

NO	PARTS	MATERIAL	QTY	FINISHING	X. ±0.35	X.* ±2*	UNITS	mm	雅安科技有限公司 ACCURATE INNOTECH INC.					
4	COVER	PBT	1	UL94V-0	.X ±0.3	.X.* ±1*	MAT'L		TITLE: USB AF 180° DIP 14.5mm 弯脚		PART NO.: USAF-04*N-1*P63			
3	HOUSING	PBT	1	UL94V-0	.XX ±0.25	.XX*	SEE NOTE		DR: gan 2012/6/29		DWG NO.: AII-P63			
2	SHELL	COPPER ALLOY	1	PLATED NICKEL	.XXX ±0.15	.XXX*	FINISH		CHKD: gan 2012/6/29		SCALE	SHEET	REV.	CUSTOMER
1	TERMINAL	COPPER ALLOY	4	PLATED GOLD/TIN	THESE DRAWINGS AND SPECIFICATIONS ARE THE PROPERTY OF ACCURATE INNOTECH INC AND SHALL NOT BE REPRODUCED, COPIED OR USED IN ANY MANNER WITHOUT THE PRIOR WRITTEN CONSENT OF ACCURATE INNOTECH INC.			Q'TY		APPD:	1:1	1/1	B	DRAWING