

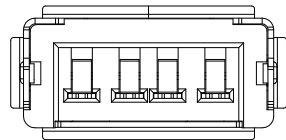

RoHS  
Compliant  
2002/95/EC

REV.	ECN.	NO.	APPD.

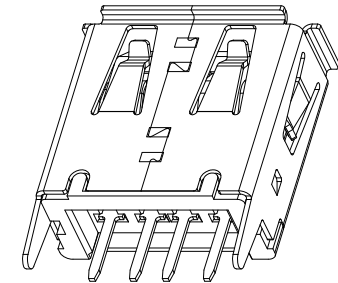
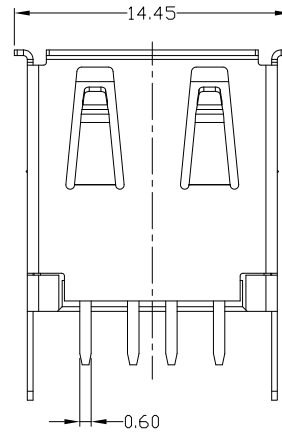
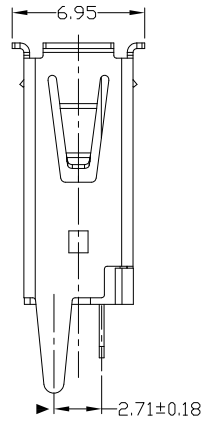
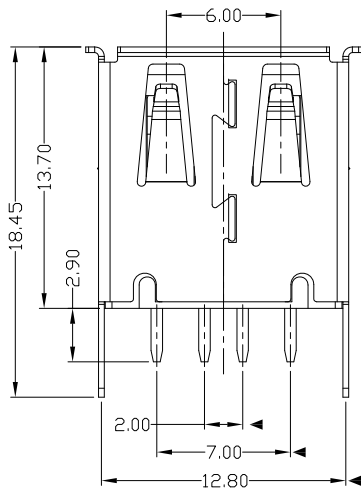
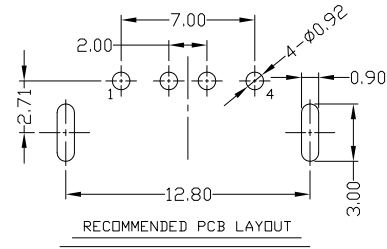
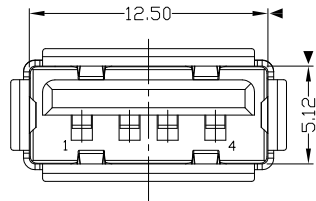

NOTES:

- ELECTRICAL:
  - VOLTAGE CURRENT RATING: 2AMP, 30V AC;
  - INSULATION RESISTANCE: 1000MΩ, MIN;
  - CONTACT RESISTANCE: 30mΩ MAX;
  - WITHSTANDING VOLTAGE: 500V AC;
  - OPERATING TEMPERATURE: -55°C TO +85°C.
- Mechanical:
  - Mating Force: 35N MAX
  - Unmating Force: 10N MIN.
- NOTE: 1. DIMENSIONS MARKED "▼" TO BE CHECKED BY Q.C & IPQC.

4. PART NO.

USA-F-04\*N-1\*P67

1: Au 1U\*  
6: Au 30U\*

W: WHITE  
B: BLACK  
1: PBT  
2: PA6T  
3: PA9T  
4: LCP

Bill of materials:

NO	PARTS	MATERIAL	QTY	FINISHING	UNITS	mm	雅安科技有限公司 ACCURATE INNOTECH INC.				
3	HOUSING	PBT+30%GF	1	UL94V-0	X. ±0.35	X.' ±2'	TITLE: USB A/F全包直脚插板式(13.7)	PART NO.: USA-F-04*N-1*P67			DWG NO.: AII-P67
2	SHELL	COPPER ALLOY	1	PLATED NICKEL	.X ±0.30	.X' ±1'					
1	TERMINAL	COPPER ALLOY	4	PLATED GOLD/TIN	.XX ±0.25	.XX'	CHKD: gan 2012/6/30	SCALE	SHEET	REV.	CUSTOMER
NO	PARTS	MATERIAL	QTY	FINISHING	.XXX ±0.15	.XXX'	APPD: gan 2012/6/30	1:1	1/1	B	DRAWING

THESE DRAWINGS AND SPECIFICATIONS ARE THE PROPERTY OF ACCURATE INNOTECH INC AND SHALL NOT BE REPRODUCED, COPIED OR USED IN ANY MANNER WITHOUT THE PRIOR WRITTEN CONSENT OF ACCURATE INNOTECH INC.

