

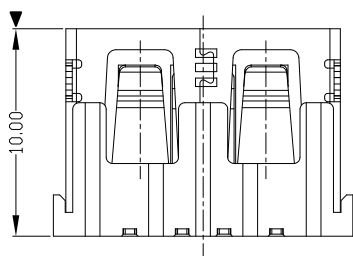

RoHS  
Compliant  
2002/95/EC

REV	LTR	DESCRIPTION	DATE	REVISER	APPD

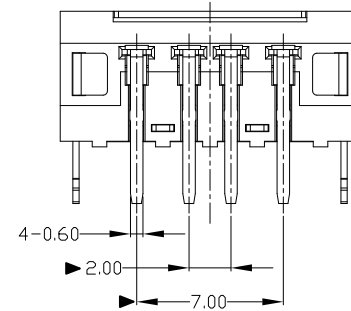
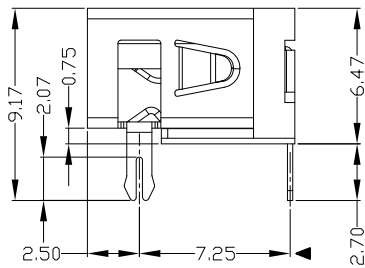
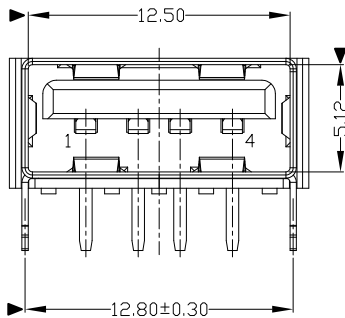
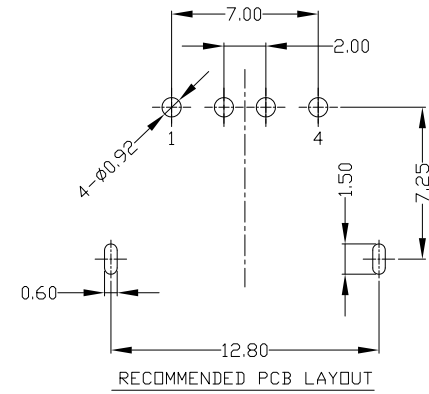
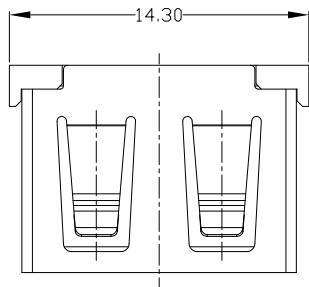

NOTES:

- ELECTRICAL:
  - VOLTAGE CURRENT RATING: 2AMP, 30V AC;
  - INSULATION RESISTANCE: 1000MΩ, MIN;
  - CONTACT RESISTANCE: 30mΩ MAX;
  - WITHSTANDING VOLTAGE: 500V AC;
  - OPERATING TEMPERATURE: -55°C TO +85°C.
- Mechanical:
  - Mating Force: 35N MAX
  - Unmating Force: 10N MIN.
- NOTE: 1. DIMENSIONS MARKED " " TO BE CHECKED BY Q.C & IPQC.

4. PART NO.

USAF-04\*N-1\*R613

1Au 1U"  
6Au 30U"

W: WHITE  
B: BLACK

1-PBT  
2-PA6T  
3-PA9T  
4-LCP

Bill of materials:

NO	PARTS	MATERIAL	QTY	FINISHING	UNITS	mm	雅安科技有限公司 ACCURATE INNOTECH INC.						
3	HOUSING	PBT	1	UL94V-0	X. ±0.35	X.' ±2'	MAT'L	TITLE:		PART NO.:			
2	SHELL	COPPER ALLOY	1	PLATED NICKEL	.XX ±0.30	.X' ±1'		SEE NOTE	USB AF DIP 90° (10.0)无卷边		USAF-04*N-1*R613		
1	TERMINAL	COPPER ALLOY	4	PLATED GOLD/TIN	.XXX ±0.15	.XXX'	FINISH	DR: gan 2013/4/12		DWG NO.:			
							SEE NOTE	CHKD: gan 2013/4/12		AII-R613			
							Q'TY	APPD:		SCALE	SHEET	REV.	CUSTOMER
										1:1	1/1	B	DRAWING

THESE DRAWINGS AND SPECIFICATIONS ARE THE PROPERTY OF ACCURATE INNOTECH INC AND SHALL NOT BE REPRODUCED, COPIED OR USED IN ANY MANNER WITHOUT THE PRIOR WRITTEN CONSENT OF ACCURATE INNOTECH INC.

